

Shibaura Machine

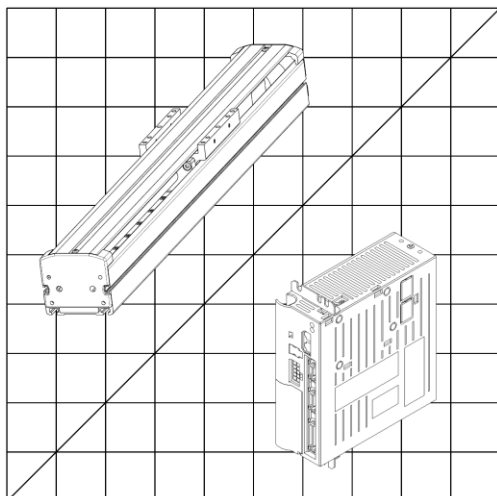

COMPO ARM

BA-III SERIES

ACTUATOR INSTRUCTION MANUAL

Original Instructions

Shibaura Machine

Keep this manual nearby for future reference.

Introduction

Before using the COMPO ARM BA-III series, read through and completely understand this instruction manual to assure correct use.

For general information for the COMPO ARM BA-III Series, refer to CA25 Instruction Manual (Basic Part).

CAUTION

1. About application of this product
 - This product is not designed or manufactured to be used in equipment in situations that can affect or endanger human life.
 - When considering this product for operation in special applications (passenger transportation, medical, aerospace, atomic power, electric power, etc.), please contact our sales section.
 - Although this product was manufactured under conditions of strict quality control, you are strongly advised to install safety devices to forestall serious accidents when it is used in facilities where a breakdown in the product is likely to cause a serious accident.
2. This equipment does not have an explosion-proof structure. Take utmost care of the operating environment.
3. All efforts have been made to assure the contents of this manual. If you have any questions, or find any mistakes, however, please contact Shibaura Machine.
4. Shibaura Machine will not be held responsible for any effects caused by using this equipment, regardless of Item 3 above.
5. The contents of this manual are subject to change without prior notice to effect improvements.

Copyright 2022 by SHIBAURA MACHINE CO., LTD..

All rights reserved.

No part of this document may be reproduced in any form without obtaining prior written permission from SHIBAURA MACHINE CO., LTD..

The information contained in this manual is subject to change without notice to effect improvements.

Contents

Chapter 1	Safety	3
■ 1.1	Cautions for safety	3
■ 1.2	For your safe operation	7
■ 1.3	Warranty	15
Chapter 2	Explanation on Axis Configuration Parts	16
■ 2.1	Angle Bracket (Bracket)	16
■ 2.2	Controller Cable	16
■ 2.3	CN Box	17
■ 2.4	Flexible Duct	17
■ 2.5	Flexible Tube	17
Chapter 3	Installing Actuator (Axis)	18
■ 3.1	Installing Actuator (Axis)	19
■ 3.2	Connecting Cable with Actuator End	20
■ 3.3	Mounting Angle Bracket	22
■ 3.4	Connecting Flexible Duct and Cable	23
■ 3.5	Connecting Flexible Tube and Cable	27
■ 3.6	Mounting, Wiring and Piping of Hand	37
■ 3.7	Mounting Duct Tray	38
■ 3.8	Mounting Tube Tray	39
■ 3.9	Bolt and Nut tightening torque	41
Chapter 4	Installing X-Y Combination Axes	42
■ 4.1	BE10-BE10 , BE30-BE10 (X-Y) Combination	42
■ 4.2	BE50-BE30 (X-Y) Combination	45
Chapter 5	Installing X-Y-Z Combination Axes	50
■ 5.1	BE50-BE30-BE10 (X-Y-Z) Combination	50
Chapter 6	Maintenance and Inspection	55
■ 6.1	Cautions on Maintenance and Inspection	55
■ 6.2	Inspection before Starting Operation	57
■ 6.3	Regular Inspection	57
■ 6.4	Maintenance and inspection work	57
■ 6.5	Lubricating Each Part	58
■ 6.6	Cleaning	58
■ 6.7	Spare Parts	58
Chapter 7	Product disposal	59
■ 7.1	Product disposal	59

Overview

This manual describes the installation methods when the actuator is used as the single axis and is used in combination with other equipment.

For the combined use, only the basic X-Y combination and X-Y-Z combination is explained in this manual.

Chapter 1 Safety

■ 1.1 Cautions for safety

- Before the installation, programming, operation, maintenance and inspection of the equipment, be sure to read through this manual so that you can use the COMPO ARM with safety.
- After you have read this manual, keep it nearby for future reference.

Be sure to observe the instructions for ensuring operation safety of the COMPO ARM.

This manual contain the important information to prevent injury to the operators and persons nearby, to prevent damage to assets and to assure correct use of the equipment.

Make sure that you have well understood the following details (indications and symbols) before reading this manual.

Always observe the information that is noted.

 **WARNING** : If you have neglected this instruction and caused a handling error, death or serious injury may occur.

 **CAUTION** : If you have neglected this instruction and caused a handling error, human injury or property damage (damages to houses, household goods and domestic animals) may occur.

 **CAUTION** : This gives a brief description of the major points of operation procedures, precautions and method for effective use of the machine.

⚠ WARNING

- **Install the safety fences to prevent anyone from entering the working envelope of the robot.**

When the door is attached to the safety fence, the robot should be stopped at emergency at the same time that the door has opened.

- **Connect the EMERGENCY STOP pushbutton switch to the emergency stop input terminal of the controller and mount the same switch at an easy-to-operate place in an emergency.**

The EMERGENCY STOP switch must not be reset automatically and cannot be reset negligently by any person.

- **Wiring should be done safely and completely according to the Electrical Installations Technical Requirements and Interior Wiring Requirements of Japan.**

Incorrect wiring will result in an electric shock or a fire.

- **The equipment MUST NOT be repaired or modified without prior written permission from the manufacturer.**

Otherwise, an accident or damage will be caused.

- **Before the maintenance and inspection, be sure to turn off the controller main power switch. Take all necessary measures to prevent anyone other than the worker engaged in adjustment of the robot from negligently turning the power on. (Lock the switch and put a tag showing "DO NOT turn the power on.") Also, DO NOT touch the controller interior three (10) minutes after the power is turned off.**

Otherwise, you may get an electric shock due to residual voltage of the capacitor.

- **DO NOT touch the motor, heat sink and cement resistor in the controller.**

They are too hot and you may get burnt. Before performing inspection, take enough time to cool them off.

- **DO NOT pour water on the equipment interior or exterior, or drain water from it. Otherwise, you may get an electric shock, or the equipment will be damaged.**

When the equipment has contaminated, wipe it off with a hard squeezed cloth. DO NOT use a thinner, benzine or other organic solvent.

- **Do not bring liquids such as water near the robot.**

Spill it, get an electric shock.

- **DO NOT throw away metals, combustibles or other contaminant into the opening of this equipment.**

A fire or an electric shock will be caused.

- **DO NOT put your finger or hand on the movable part or opening of the equipment.**

Otherwise, you may get injured.

- **When using the actuator in other than the horizontal state, be sure to select the actuator with brake.**

Otherwise, the slider will drop at power OFF, and you will be injured.

⚠ WARNING

- **As the equipment is heavy, make sure of its weight and gravity center position and disconnect the cables when carrying the equipment.**

Also, DO NOT carry the equipment with the slider. Otherwise, the slider will move and you will get injured.

- **DO NOT use this equipment for the living body as a massaging machine.**

Otherwise, you will be injured due to incorrect teaching or mis-operation.

- **This equipment has not a sealed structure. During use, grease of the ball screw or wear of the belt may scatter from the opening of the equipment.**

When using this equipment for food and chemical applications, take appropriate measures against entry of them.

- **Enter the robot type and initialize the memory correctly.**

Otherwise, the robot may move unexpectedly and you will be injured.

- **DO NOT use this equipment in an atmosphere of inflammable gas or an atmosphere inducing an explosion.**

As this equipment is not explosion-proof, it may explode in the worst occasion.

- **DO NOT damage, break, process, forcibly bend, stretch, place a heavy object on or pinch the cables (power cable, controller cable).**

Otherwise, an electric shock or a fire will be caused.

- **Should an abnormality such as smoke or nasty smell occur, turn the power off immediately and stop using the equipment.**

If the equipment is used continuously, an electric shock or a fire will be caused.

When using the side mounted motor axis in the vertical condition, be sure to check for the belt on a regular basis. Replace the belt every 3,000-hour operation.

If the belt whose service life already ended is used continuously, it may be broken or the slider may drop, and you will be injured.

⚠ CAUTION

- **DO NOT place the equipment at a place where the ambient temperature exceeds 40°C, or where the temperature changes sharply, causing condensing, or where it is exposed to direct sunlight.**

Additionally, if the equipment is installed at a narrow place, the ambient temperature rises due to heat generation in the controller itself or external device, which will result in malfunction or mis-operation of the equipment.

- **DO NOT use the equipment at a place where an impact or vibration is involved. Also, DO NOT use the equipment in an atmosphere where conductive dust, corrosive gas or oil mist generates.**

Otherwise, a fire, electric shock, malfunction or mis-operation will be caused.

- **DO NOT use the equipment at a place where too much dust or dirt exists.**

If the equipment is used at such a place, it may malfunction because this equipment is not dust-proof.

- **DO NOT use repair parts other than those designated by the manufacturer.**

Otherwise, the equipment cannot be operated to its full capacity and will cause malfunction.

- **Mount the robot on a highly rigid frame.**

If rigidity of the frame is not enough, vibration (or resonance) may be caused during the robot operation, adversely affecting the operation.

- **In the case of power failure, this equipment becomes a free running state. When devices or work pieces may be damaged by free running of this machine, use an axis equipped with brake even if the axis is installed horizontally.**

This machine does not have a dynamic brake function.
The brake of this machine is a holding brake. The holding brake cannot be used for deceleration.
If you want to use it as a used for deceleration, please contact us.

- **Do not apply force to the slider that exceeds the maximum speed of this machine. It may cause a malfunction.**

- **Do not connect or disconnect a connector with the controller turned ON.**

Malfunction may be caused.

- **Take safety measures against fall and scatter of a work piece.**

If collision occurs, the axis decelerates suddenly and a work piece may fall and scatter.

- **Perform risk assessment for entire equipment and take required protective measures.**

- **When discarding this product, dispose correctly as an industrial waste.**

■ 1.2 For your safe operation

When you use the COMPO ARM BA-III series, be sure to take the measures in conformity to the following instruction:

This machine is an industrial robot in conformance to the provisions of Paragraph 31 of Article 36 of the Ordinance on Industrial Safety and Hygiene. Necessary cautions are specified in the "Selection", "Installation", "Use", "Periodic Inspection, etc." and "Education" of the "Technical Guideline on Safety Standards for Use of Industrial Robot" conforming to the Article 28 of the Industrial Safety and Health Law. You are requested to read them carefully and to observe the instructions. The following introduces some of them.

■ 1.2.1 Safety measures

(1) A safety barrier shall be provided to ensure that any person cannot enter the working area of a robot.

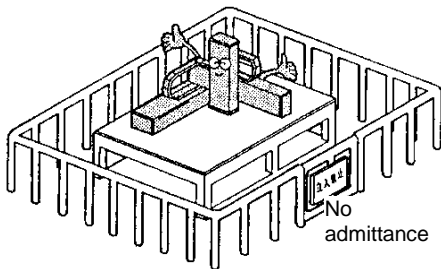

1. The barrier shall have sufficient strength to withstand the force generated during the work or environmental conditions. The barrier shall have such a structure that cannot be easily adjusted, removed or cleared.
2. The safety barrier shall be free from any serrated or sharp edge or protrusions.
3. The safety barrier shall be designed in a stationary structure.
4. When a safety barrier is equipped with a door, an interlock shall be provided so that the robot will be stopped by opening of the door.

(2) An emergency stop device shall be installed where the robot can be easily stopped by the operator immediately in the event of emergency.

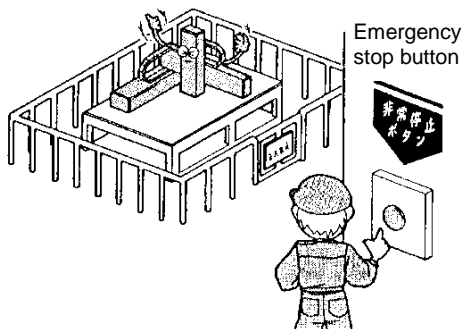

1. The emergency stop function shall ensure immediate and reliable stop of a robot when the emergency stop button switch has been operated by an operator.
2. The emergency stop button shall be red.
3. The emergency stop device shall be located so that it can be easily pulled, pressed or touched by the operator, and it can block a beam of light.
4. The emergency stop button shall be structured in such a way that it is not automatically reset after having been operated, and cannot be reset carelessly.

(3) For safety, never modify the robot main unit or control device.

■ 1.2.2 Precautions during transportation

Note the following points when transporting the robot.

- (1) When upload the packing boxes from a truck, never lift it by hand.
The packing box could fall on persons.
 - Use a forklift and the like
 - Do not allow people near the transportation route
- (2) Never carry the packing boxes by hand.
The packing box could fall on a worker.
 - Use a lifter or the like.
 - Do not allow people near the transportation route.
- (3) Never carry the robot manually.
The robot could fall without being able to support it.
 - Please lift it with a crane or the like.
 - Please use a dolly to reach the destination.
 - Secure a transportation route so that a fallen robot does not collide with a person.
 - Wear protective gloves and protective shoes.
- (4) When removing the product from the packing box, never lift it in an unreasonable position.
Excessive strain can hurt your back.
 - Secure a space where you can work comfortably.
- (5) Be sure to store the cables that crawl on the floor in a duct or the like.
Stumbling and falling could occur.
 - Wear a helmet to protect your head.
- (6) Be sure to follow the instructions below when lifting the robot.
The robot could fall.
 - Use a wire with a limited load that can withstand the weight of the robot.
 - Be sure to lift and lower the robot slowly.
 - Secure a transportation route to prevent people from entering under the suspended load.
- (7) When transporting the assembly/shipment machine, be sure to use the attached fixing jigs to fix the slider.
It is caught in the moving rider part.
 - Check whether the jig bolts loosens or not.
 - Wear protective gloves to prevent slipping and protect your hands.
- (8) Place the robot in a stable position at the disposal site.
Otherwise, the robot will fall down.
 - If possible, ensure safety and then lay it on its side.
- (9) After transportation, be sure to check that the robot is not damaged.
When you turn on the broken robot, you will be hit by the robot that behaves unexpectedly.
 - Check the appearance according to the outline drawing described in the manual.
 - Check the appearance of the attached parts according to the list attached to the controller.
 - If you find any damage or missing parts, please contact our sales department.
- (10) Before touching the robot, make sure that the surface temperature is below 50°C.
If you touch the hot motor or the area around the motor, you will get burned.
 - If necessary, wear protective gloves.
- (11) Before transportation, be sure to turn off the power, disconnect the cable from the controller, and then remove the robot.
If the robot falls and touches the broken cable, you will get an electric shock.

[About the work of suspending the robot with a crane]

1. Work must be carried out by qualified personnel.
2. Use equipment that can withstand the weight of the items to be transported.

For the mass of the actuator, refer to the specifications of each actuator instruction or CE Specifications Installation Manual (ST1258) depending on the product.

3. Use a belt sling to prevent damage to the actuator to be lifted.
4. Please remove the vinyl wrapping the actuator when hanging it.
If the actuator is wrapped in plastic, the actuator will slip and fall when suspended.
5. As shown in the figure below, hang the product in two places.

Suspend at a position about $\frac{2}{3}$ of the full length L of the actuator.

Also, please use a belt slings with a length that makes the angle between the two belt slings about 60 degrees. If the hanging angle is extremely narrower than 60 degrees or if it greatly exceeds, the actuator may slip and fall.

Also, adjust the hanging position according to the center of gravity so that the conveyed item is level and does not slip off.

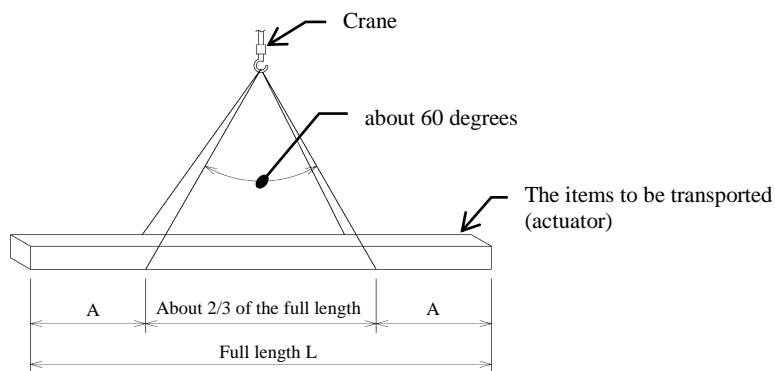

Suspended state by crane

* If the items to be transported do not have eyebolts or other fixed hanging tools and fall under any of the following conditions, do not suspend them and transport them using a forklift, etc.

- When full length L is 600mm or less
- When the A dimension is 150 mm or less

6. If the belt sling comes off the actuator during lifting, use the T-slot on the bottom of the frame for fixing the actuator to fix hoisting tools such as eyebolts before hoisting.

If the belt sling is not fixed, the actuator will slip and fall when suspended.

■ 1.2.3 Notes on unpacking and repacking

Note the following points when unpacking and repacking the robot.

- (1) When upload the packing boxes from a truck, never lift it by hand.
The packing box could fall on persons.
 - Use a forklift and the like
 - Do not allow people near the transportation route
- (2) Never carry the packing boxes by hand.
The packing box could fall on a worker.
 - Use a lifter or the like.
 - Do not allow people near the transportation route.
- (3) After unpacking, be sure to check that the robot is not damaged.
When you turn on the broken robot, you will be hit by the robot that behaves unexpectedly.
 - Check the appearance according to the outline drawing described in the manual.
 - Check the appearance of the attached parts according to the list attached to the controller.
 - If you find any damage or missing parts, please contact our sales department.
- (4) When cutting the string of packing box with a knife, never point the blade in the direction of the person.
Will be cut by the knife.
 - Use nippers or scissors.
 - Please wear protective gloves.
- (5) Never carry the robot manually.
The robot could fall without being able to support it.
 - Please lift it with a crane or the like.
 - Please use a dolly to reach the destination.
 - Secure a transportation route so that a fallen robot does not collide with a person.
 - Wear protective gloves and protective shoes.
- (6) When taking the product out of the packing box or putting it in, never lift it in an unreasonable position.
Excessive strain can hurt your back.
 - Secure a space where you can work comfortably.
- (7) When transporting the assembly/shipment machine, be sure to use the attached fixing jigs to fix the slider.
It is caught in the moving rider part.
 - Check whether the jig bolts loosens or not.
 - Wear protective gloves to prevent slipping and protect your hands.
- (8) Before touching the robot, make sure that the surface temperature is below 50°C.
If you touch the hot motor or the area around the motor, you will get burned.
 - If necessary, wear protective gloves.
- (9) Be sure to store the robot in the packing box and fix it as it was delivered.
The robot will fall down.
 - Customers are requested to prepare a new cord (PP band).
 - If there is no packing box, use the mounting holes on the frame to fix it.
- (10) Be sure to follow the instructions below when lifting the robot.
The robot could fall.
 - Use a wire with a limited load that can withstand the weight of the robot.
 - Be sure to lift and lower the robot slowly.
 - Secure a transportation route to prevent people from entering under the suspended load.
- (11) Be sure to store the cables that crawl on the floor in a duct or the like.
Stumbling and falling could occur.
 - Wear a helmet to protect your head.

■ 1.2.4 Precautions for installation

Observe the following instructions when installing a robot:

- (1) The robot shall be laid out to ensure the work space required for robot teaching, maintenance and inspection.
- (2) The robot controller, other controllers and stationary operation panel shall be installed outside the movable range and where the operator can watch the robot operations.
- (3) The pressure gauge, hydraulic pressure gauge and other instruments shall be installed in clearly visible positions.
- (4) The electric wiring and hydraulic/pneumatic piping shall be provided with protective covers if they may be damaged.
- (5) To ensure effective operation of the emergency stop device in the event of emergency, emergency stop device switches shall be installed on locations other than the operation panel, as required.
- (6) Be sure to install the robot before connecting the cable to the controller.
Get an electric shock by touching the robot or the cable that has fallen and is broken.
 - Do not turn on the power if the cable is broken.
- (7) Be sure to store the cables that crawl on the floor in a duct or the like.
Stumbling and falling could occur.
 - Wear a helmet to protect your head.
- (8) Before turning on the power, make sure that the ground wire is connected.
If you touch the robot, you will get an electric shock due to the leakage current.
- (9) Before servo-on the robot, make sure that no one is within the robot's range of motion.
The person inside is struck by the robot that has moved.
- (10) Don't place equipment that generates excessive noise near the robot.
Collision could be happen with the robot that has malfunctioned due to noise.
- (11) When removing the fixing jig, never squeeze the corners.
If excessive force is applied, the hand or finger will be cut with a jig.
 - Please wear with protective gloves.
 - The bolts that are fastened may become stiff due to vibration during transportation or carrying.
- (12) Never install the robot on a stand cannot withstand the load during operation.
The robot collapses together with the stand during operation.
- (13) Use a hand with a structure and wiring that does not release the work even if the power supply of the robot or the drive source of the hand is cut off.
 - Perform daily inspections of the air tube connected to the hand, and replace it if it is damaged.
 - Install a fence to prevent falling and flying objects.
- (14) After working, be sure to check that the robot is not damaged.
When you turn on the broken robot, you will be hit by the robot that behaves unexpectedly.
 - Check the appearance according to the outline drawing described in the manual.
 - Check the appearance of the attached parts according to the list attached to the controller.
 - If you find any damage or missing parts, please contact our sales department.
- (15) Do not modify anything other than the permitted parts.
A broken robot causes an unexpected disaster.
- (16) The equipment **MUST NOT** be repaired or modified without prior written permission from the manufacturer.
Otherwise, an accident or damage will be caused.
- (17) Be sure to lock the connector of the robot and fix the cable.
If the connector is overloaded and pulls out, the hand will behave unexpectedly.
 - Adjust the wiring and piping of the robot to see if they are in contact with the robot or peripheral devices, or if the connector is under load, while checking the operating conditions of the robot.
- (18) Be sure to turn off the power, disconnect the cable from the controller, and then remove the robot.
If the robot falls and touches the broken cable, you will get an electric shock.

■ 1.2.5 Precautions for use

Observe the following instructions when using a robot:

1. Before turning on the power, make sure that the ground wire is connected.
If you touch the robot, you will get an electric shock due to the leakage current.
2. Don't place equipment that generates excessive noise near the robot.
Collision could happen with the robot that has malfunctioned due to noise.
3. Before servo-on the robot, make sure that no one is within the robot's range of motion.
The person inside is struck by the robot that has moved.
4. Be sure to perform regular maintenance and inspection.
If maintenance and inspection are neglected, a broken robot could cause an unexpected disaster.
5. Before touching the robot, make sure that the surface temperature is below 50°C.
If you touch the hot motor or the area around the motor, you will get burned.
 - If necessary, wear protective gloves.
6. Never install the robot on a stand cannot withstand the load during operation.
The robot collapses together with the stand during operation.
7. Use a hand with a structure and wiring that does not release the work even if the power supply of the robot or the drive source of the hand is cut off.
 - Perform daily inspections of the air tube connected to the hand, and replace it if it is damaged.
 - Install a fence to prevent falling and flying objects.
8. Be sure to lock the connector of the robot and fix the cable.
If the connector is overloaded and pulls out, the hand will behave unexpectedly.
 - Adjust the wiring and piping of the robot to see if they are in contact with the robot or peripheral devices, or if the connector is under load, while checking the operating conditions of the robot.

[Work within the movable range]

(1) Work provisions

Determine provisions for the following items and perform the work in conformity to them:

1. Root operation methods and procedures required in the work such as startup method and switch handling method.
2. Speed of robot main unit in teaching.
3. Signaling method for work adjustment among more than one operator.
4. Action to be taken by the operator for each problem.
5. Procedures for confirming the release of the emergency and safety when restarting the robot operation after the robot operation has been stopped due to the operation of the emergency stop device.
6. Measures to protect against the hazard due to unexpected operation of the robot described below (in addition to the above items), or the hazard caused by a robot operation error.
 - Indication on the operation panel.
 - Measures to ensure safety of the operator working within the movable range.
 - Working position and posture.
 - Prevention of operation error due to noise.
 - Signaling method for work adjustment with operators of related devices.
 - Error type and evaluation procedure.
7. The work provisions shall meet the requirements of the robot type, installation site and work.
8. The work provisions shall be prepared by consultation with the related operators, manufacturer's engineers and industrial safety consultant.

(2) Indication on the operation panel

To ensure that the start switch and selector switch will not be carelessly operated by a person other than the personnel in charge of this work, the switch shall be provided with an easy-to-read indication to show that the work is in progress. Alternatively, the operation panel cover shall be provided with locking or other means.

(3) Measures to ensure the operation safety of the personnel working within the movable range

Any one of the following measures or other measures on the equal or higher level shall be taken so that you can stop the robot operation immediately in the event of an error when working within the movable range:

1. An adequately authorized supervisor shall be assigned outside the movable range and where the robot operations can be observed. This supervisor shall be exclusively in charge of the supervision and shall be responsible for the following:
 - The supervisor shall cause the emergency stop device to be operated immediately in the event of an error.
 - The supervisor shall ensure that a person other than the personnel in charge of this work is kept outside the movable range.
2. The emergency stop device switch shall be placed under the control of the person working within the movable range.
3. A portable operation panel having a structure capable of on/off operation of the power source, oil hydraulic or pneumatic source shall be used in the work.

(4) Inspection prior to start of the work such as teaching

Prior to start of the work such as teaching, the following items shall be inspected. If any error is detected, immediately repair the trouble or take other required action.

1. Check if the covering or sheathing of the external power source is damaged or not. (This check must be made after the power has been turned off).
2. Check if the operation of the robot proper is faulty.
3. Check for the functions of the braking device and emergency stop device.
4. Check if there is any leakage of air or oil from the piping.

(5) Cleaning of working tools

When such working tools as a painting nozzle are mounted on the robot proper, and these working tools must be cleaned, it is preferred that these tools should be automatically cleaned so that the number of machines entering the movable range can be minimized.

(6) Release of residual pressure

Before disassembling the pneumatic components or replacing their parts, release the residual pressure in the drive cylinder.

(7) Operation check

Perform the verification operation without entering the movable range, wherever possible.

(8) Illuminance

The illuminance required for operation safety shall be maintained.

[For automatic operation]

(1) Action before startup

Before starting the robot, check for the following items in advance and determine a signaling method for work adjustment among related operators.

1. Make sure that there is no person within the movable range.
2. The movable operation panel and tools shall be located at specified positions.
3. There shall be no error indication for the robot or related devices.

(2) Action for automatic operation and in the event of an error

1. Make sure that there is an indication to show that the automatic operation is now in progress, after the robot has been started.
2. When a problem has occurred to the robot or related device and you have to enter the movable range to take emergency measures, stop the robot operation, for example, by operating the emergency stop device before entering the movable range. At the same time, carry a safety plug with you, and ensure that the start switch is provided with the indication to show that the work is now in progress. Take measures so that any other person than the operator in charge of the emergency measures cannot operate the robot.
3. When a person is caught in a robot, take measures to prevent the robot from starting at the time of rescue. You could be hit by a robot activated by a third party.
 - If there is no problem with rescue, make an emergency stop.
 - If there is no problem with rescue, keep the safety door open.
 - Do not turn off the power of the controller. The brake on the axis cannot be released.

Requesting your cooperation

For the safety instructions which seem especially important, relevant warning label is attached to the equipment.

When the label attached to the equipment has peeled off or the characters are defaced and unreadable, please procure it from our sales agent in your territory by specifying the part number, and attach it to the original place.

Warning label for actuator

Part number: 55620157



WARNING

- Before the installation, programming, operation, maintenance and inspection of the equipment, be sure to read through this manual so that you can use the COMPO ARM with safety.
- Install the safety fences to prevent anyone from entering the working envelope of the robot.
- DO NOT put your finger or hand on the movable part or opening of the equipment. Otherwise, you may get injured.
- When using the actuator in other than the horizontal state, be sure to select the actuator with brake. Otherwise, the slider will drop at power OFF, and you will be injured.

■ 1.3 Warranty

■ 1.3.1 Warranty period

This product is warranted for one of the following periods whichever comes first.

- (1) For 24 months after shipment from our factory.
- (2) For 18 months after installation at the customer's factory.
- (3) For 4000 hours of operation.

■ 1.3.2 Details of warranty

- (1) This product is warranted. The scope of the warrant includes the specifications and functions described in the Specification, catalog and Instruction Manual. We are not responsible for any secondary or incidental damages caused by the trouble of this product.
- (2) We will repair, on a free-of-charge basis, the trouble caused in the handling or use of the product within the warranty period of this product as described in the Instruction Manual attached to this product. Alternatively, such trouble will be repaired after the product has been returned to our factory. If the problem is solved by a dispatch of service personnel to meet the convenience of the customer, we may claim payment from your company regarding the transportation expenses, lodging expenses or other expenditures not directly related to the repair of the product.

■ 1.3.3 Exemption from responsibility

The following cases shall be excluded from the scope of warrant.

- (1) The trouble and damage caused by the use of the product according to a method not described in the Instruction Manual, or by a careless error in use.
- (2) Problems caused by chronological changes or wear by use (such as natural fading of paints, deterioration of the consumable parts *1).
- (3) Problems caused by sensory phenomena (e.g. generated noise without affecting the function).
- (4) Modification or disassembling not authorized by our company.
- (5) Troubles or damages caused by inadequate maintenance and inspection or improper repair.
- (6) Troubles or damages caused by natural disaster, fire and other external factors.
- (7) Internal data such as programs and points created or modified by the customer.
- (8) Problems caused when this product purchased in Japan is brought to an overseas country.

*1 : Consumable parts are defined as the parts maintenance replacement parts (spare parts) described in the Instruction Manual of each product, and the parts (e.g. backup battery) that must be replaced on a periodic basis.

■ 1.3.4 Precautions

- (1) When you have used the product beyond the specifications of the product, we cannot warrant the basic performances of the product.
- (2) Should you fail to observe the instructions given in "WARNING" and "CAUTION" described in the Instruction Manual, we are not responsible for any personal injury, damages or trouble that may occur.
- (3) Please note that the "WARNING" and "CAUTION" described in the Instruction Manual, and other descriptions are within the scope assumed by our company.
- (4) The numerical values given as technical data are theoretical values as a guideline showing the durability and others. They shall not be construed as indicating warranty. Note that these values are subject to change according to the conditions of use.

Chapter 2 Explanation on Axis Configuration Parts

For the axis configuration, the following parts are used in addition to the actuator.

■2.1 Angle Bracket (Bracket)

- This part is used to connect multiple actuators (axes). It is roughly classified into the angle type and plate type. Select either type according to the axis combination to be used.

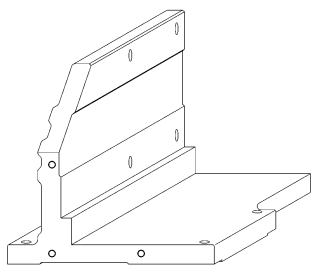

Angle type (Angle bracket)

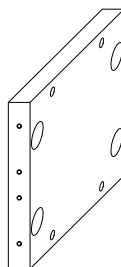
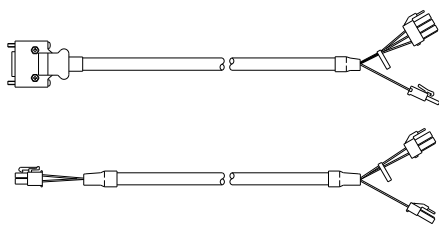

Plate type (Bracket)

■2.2 Controller Cable

- This cable connects the axis (actuator) with the controller.
One (1) set of two (2) cables for signal and power drive is provided.
- One (1) set of controller cables is required for each axis (actuator).
- As this controller cable is bending-resistant, it can be used as a movable cable.



For signal

For power drive

One (1) set

■ 2.3 CN Box

- This is the relay box for the controller cable, or the cables and air pipelines provided by the customer.
- The CN box is mounted on the axis (actuator), frame, etc.
For details on the mounting procedures, see Para. 3.4.

Note DO NOT mount the CN box in the working range of the slider or hand.

■ 2.4 Flexible Duct

- This duct is used to protect the controller cable, or the cables and air pipelines provided by the customer.
(The cables, etc., run through the duct for use.)

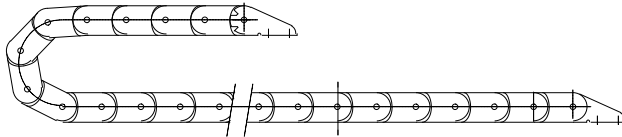

■ 2.5 Flexible Tube

- This tube is used to protect the controller cable, or the cables and air pipelines provided by the customer.
(In the case of BA10-FT-L only, in the tube, you can use through the controller cable.)
- The tube with oval cross-sectional profile : M size (BA10-FT-M) can be used for the vertical or horizontal layout.
- The tube with round cross-sectional profile : L size (BA10-FT-L) can be used for the vertical layout.

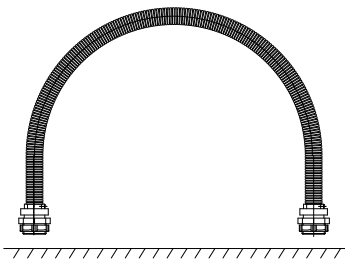

Vertical layout

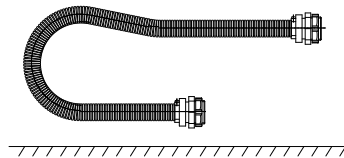

Horizontal layout

Note

When using the tube, the minimum radius of curvature should be considered. For details, see Para. 3.5.
In the BA10-FT-M, the controller cable does not enter. If you are using the controller cable through the inside of the tube, please use the BA10-FT-L.

Chapter 3 Installing Actuator (Axis)

- This chapter describes the basic installation procedures for the axis and peripheral equipment.
- Installation shall comply with the instructions of this Chapter. If the installation procedure is incorrect, robot performance cannot be achieved. Not only that, the service life may be seriously reduced.



CAUTION Precautions for installation

● Environment of installation site

(1) The ambient environment for operation shall comply with the following requirements:

- Ambient temperature Working temperature: 0°C to 40°C
 Transportation and storage temperature: -10°C to 50°C
- Relative humidity: 30 to 90%RH without dew condensation
- Altitude: 1000 m or less
- Vibration 0.98 m/s² or less
- Dust: Free from conductive dust or dirt
- Gas: Free from flammable or corrosive gas
- Magnetic field: Free from a nearby device that may generate magnetic field
- Radiation: Not in the radiation controlled area
- Others: Without greasy fume

(2) This product is not designed as an explosion proof structure. Do not use it in a dusty place. Further, take sufficient care of the environment since it is not explosion-proof.

(3) Do not use it in a place with an organic solvent or white kerosene..
Of guide or ball screw grease is melted. It may cause malfunction.

● Precautions in installation

(1) Do not allow the product to fall down or be collided with other object during the transportation.

(2) Install the product where maintenance and inspection are easier.

(3) Install the controller within the range where it can be reached from the robot proper by a standard cable.

(4) Installation

- Install the product on a horizontal installation base.
- The installation base shall have the length that allows only the frame portion to be mounted.
- The installation base should be made of steel plate which is machined to 9 mm or over in thickness for BE10 and BE30, and 20 mm or over in thickness for BE50 and BE60, and 0.2 or less in flatness. Mount the actuator on this base, then correct a bend or twist of the actuator frame and reinforce the same frame.
- Install the oval bolts (installation bolts) of the axis at a pitch of approximately 150 mm.

■ 3.1 Installing Actuator (Axis)

To install the actuator, observe the following procedures.

(1) Setting the oval bolt

From the axis end face, insert the oval bolt in the T-slots of the frame installation surface.

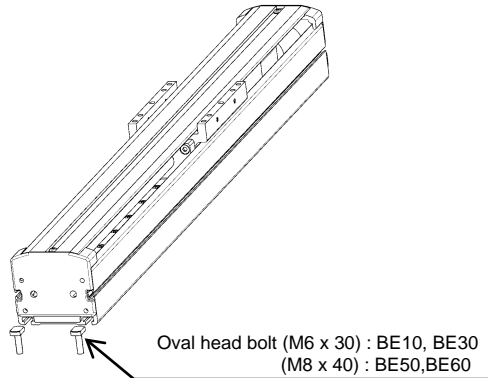

(2) Mounting on the installation base

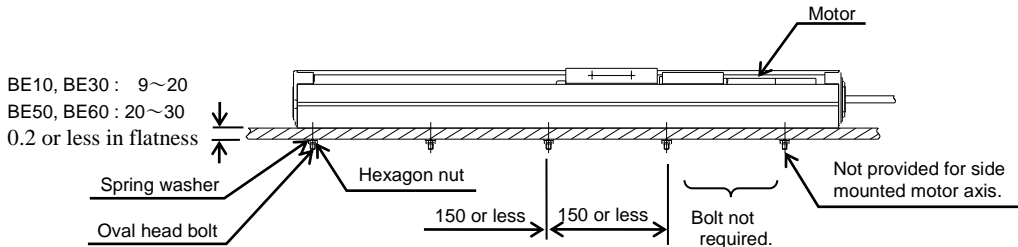

⚠ CAUTION

- The T-slots (for M4 nut) on the side and top of the frame are used to install the CN box and optical parts. Never use these T-slots to mount the axis.
- For the nut tightening torque, see Para. 3.9.

■ 3.2 Connecting Cable with Actuator End

- Cable connection (BE10)

Make sure that the cable will not enter too far.

(1)

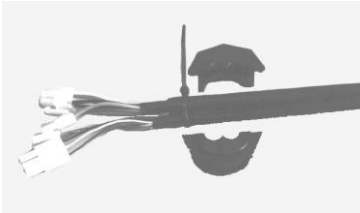

Secure the cable with a band.

(3)



Assemble the cable grip.

(5)

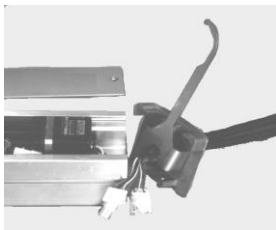

Clamp the resin nut.

(2)

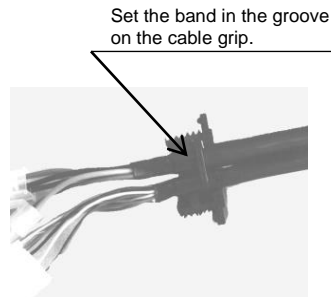

Set the band in the groove on the cable grip.

(4)

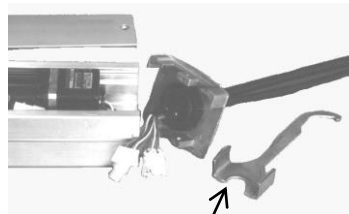

Key wrench (option)

(6)

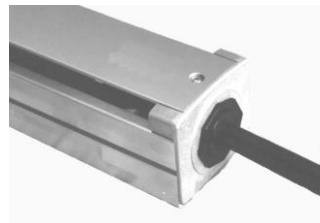

Secure the end base in place.

- Connecting the controller cable

Insert the connector for the axis side of the controller cable into the connector for the axis body (for motor power, encoder, origin sensor, brake (only with brake is connected)) until it is locked, and connect it securely. Insert the motor power connector for the controller side of the cable into the connector on the surface of the controller until it is locked, and then connect it securely. Insert the encoder connector into the connector on the surface of the controller and fix it with screws.

For the connector on the controller side, also refer to the CA25 instruction manual (Basic part).

⚠ CAUTION

- Before energizing, be sure to check that there are no connector connection leaks or connection errors.
- Do not pinch the wiring between the motor cover cap and the motor cover.
- When connecting or fixing the connector, do not apply excessive force to the cable.

- Cable connection (BE30, BE50)

Make sure that the cable will not enter too far.

(1)

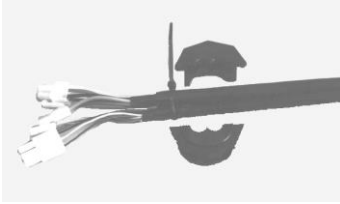

Secure the cable with a band.

(3)

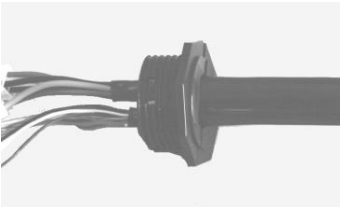

Assemble the cable grip.

(5)

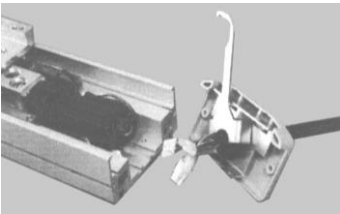

Clamp the resin nut.
(Clamp both the end plate and end cover.)

(2)

Set the band in the groove on the cable grip.

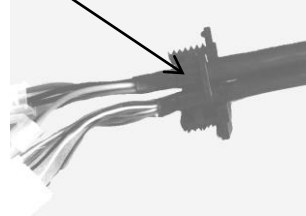

(4)

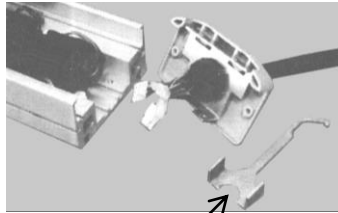

Key wrench (option)

(6)

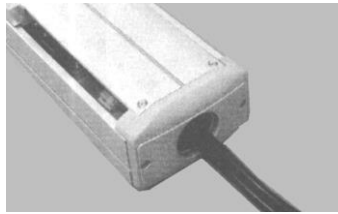

Secure the end base and cover in place.

- Connecting the controller cable

Insert the connector for the axis side of the controller cable into the connector for the axis body (for motor power, encoder, origin sensor, brake (only with brake is connected)) until it is locked, and connect it securely. Insert the motor power connector for the controller side of the cable into the connector on the surface of the controller until it is locked, and then connect it securely. Insert the encoder connector into the connector on the surface of the controller and fix it with screws.

For the connector on the controller side, also refer to the CA25 instruction manual (Basic part).

⚠ CAUTION

- Before energizing, be sure to check that there are no connector connection leaks or connection errors.
- Do not pinch the wiring between the motor cover cap and the motor cover.
- When connecting or fixing the connector, do not apply excessive force to the cable.

■ 3.3 Mounting Angle Bracket

The following explanation is made, taking the X-Y combination for example.

When using the actuator as the single axis, mount the hand provided by the customer.

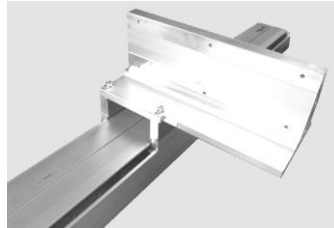
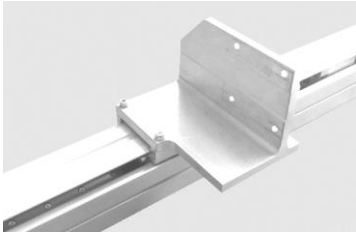

⚠ CAUTION For the bolt clamping torque, see Para. 3.9 .

(1) Mounting Y-axis

Insert the oval head bolts into the Y-axis and mount the Y-axis as shown below.

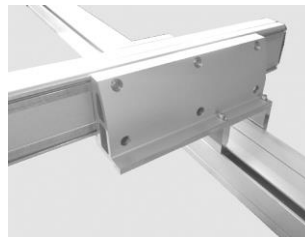
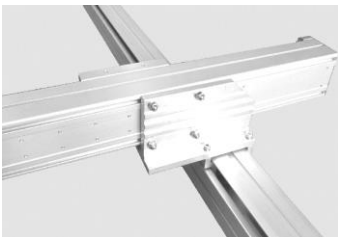

- The Y-axis should be mounted so that it can make right angles with the X-axis and run parallel with the base.

⚠ CAUTION For the nut clamping torque, see Para. 3.9.
If the sticker or warning label on the frame cover is upside down due to the axis combination, remove the frame cover, then reverse it left to right and mount it again.
For the BE30-BE10 (X-Y) combination, if the Y-axis is a straight axis, it is secured to the bracket with eight (8) oval head bolts. For the side mounted motor axis, insert the oval head bolts into the six (6) holes on the bracket in the direction of the axis (actuator) end.

Points

- The set base should be rigid enough with good flatness.
- Use the attached oval head bolts for the set bolts.
- The pitches for setting the oval head bolts should be 150 mm or less.
- T-slots on the lateral side and top of the frame are not intended for mounting the axis (actuator)

■ 3.4 Connecting Flexible Duct and Cable

The flexible duct is used to protect the controller cable, and wiring and piping from the hand.

Cut the flexible duct to an appropriate length according to the application.

(The flexible duct link can be removed easily, using a screwdriver, etc.)

For the X-Y combination, the BA10-BX-F10 CN box is used for the X-axis, and the BA10-BX-F30 for the Y-axis.

- Cautions on use of flexible duct:

When using the flexible duct, pass the controller cable, etc., through it before mounting the duct, as shown below.

When the X-axis slider is located at the end of the actuator, the flexible duct should project by about 150 mm.

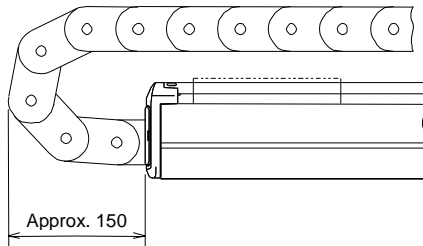

Notes

- The protruding amount of the flexible duct varies depending on the combination form. Please check with outline dimension drawing.
- If used with dimensions other than those given above, the service life of the duct will reduce drastically.
- DO NOT place too many cables, etc., in the flexible duct. Otherwise, the life of the cable will reduce sharply.

Example of connecting with X-axis (BE50)

- (1) Insert the hexagon nuts into the T-slot on the frame cover and mount the CN box on top of the actuator.
- (2) Mount the clamp plate on the CN box.
- (3) Attach the flexible duct link set metal fitting to the clamp plate. Mount the clamp base on the clamp plate.

(1)

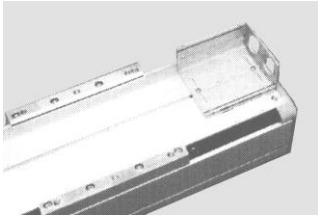

(2)

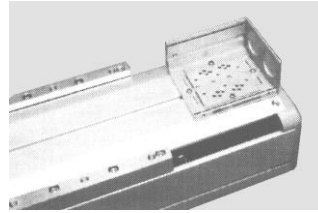

(3)

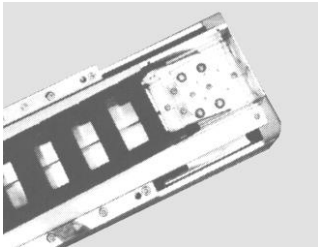

(4)

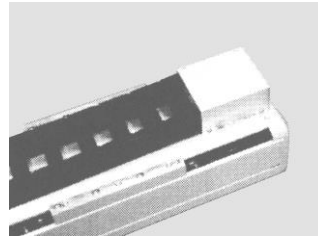

Points

- When connecting with the side of the actuator, mount the CN box on the side, then connect the flexible duct in the same manner as above.

Example of connecting with Y-axis

- (1) Insert the hexagon nuts into the T-slot on the side of the actuator and mount the CN box on the actuator.
- (2) Mount the clamp plate on the CN box.
- (3) Attach the flexible duct link set metal fitting to the clamp plate. Mount the cable clamp base on the clamp plate.

(1)

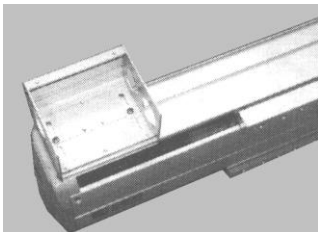

(2)

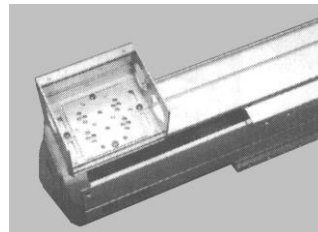

(3)

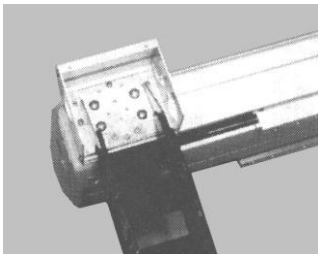

(4)

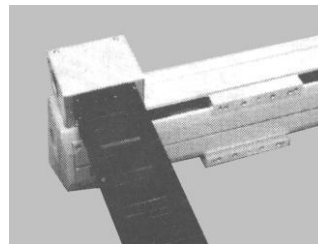

Example of cable connection (X-axis)

Assemble the cable by passing it through the required parts and flexible duct ink, or pass the cable through the flexible duct after securing the duct to the X-axis.

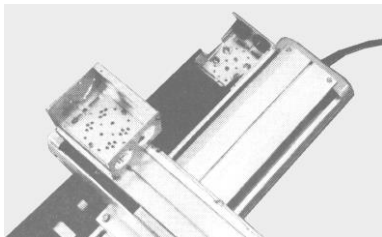

Secure the flexible duct to the X-axis.

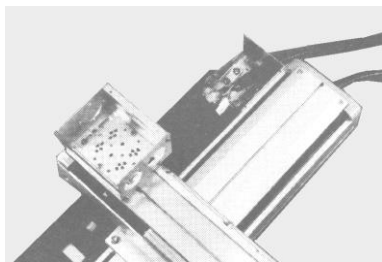

Pass the cable through the flexible duct.

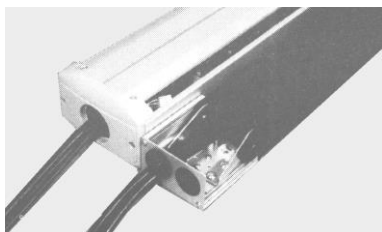

Points

- It is easy to pass the cable through the duct by bundling the cable connectors in a small vinyl bag, etc.

Example of cable connection (Y-axis)

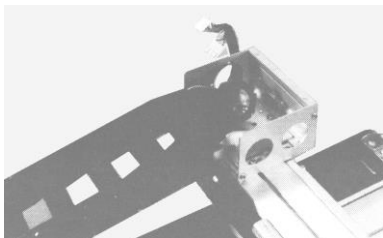

Pass the cable through the CN box and resin nut, then connect it with the Y-axis.

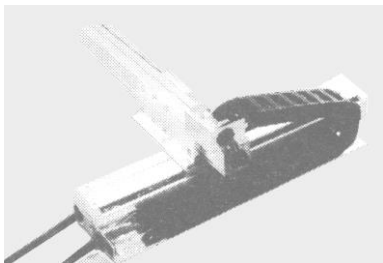

After attaching the cable grip to the Y-axis, attach the CN box cable grip.

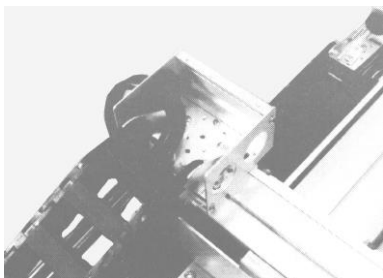

Adjust the length of the cable running from the Y-axis, then secure the cable with a band.

■ 3.5 Connecting Flexible Tube and Cable

The flexible tube is used to protect the controller cable, and wiring and piping from the hand. Cut the flexible tube to an appropriate length according to the application.

(The tube can be cut easily with a knife, etc.)

- Cautions on use of flexible tube:

When using the flexible tube, pass the controller cable, etc., through it before mounting the tube, as shown below.

The dimensional drawing below is an example of “BA10-FT-M ***”.

“BA10-FT-L ***” has the same dimensions, but “BA10-FT-L ***” cannot be used in a horizontal arrangement.

Vertical layout

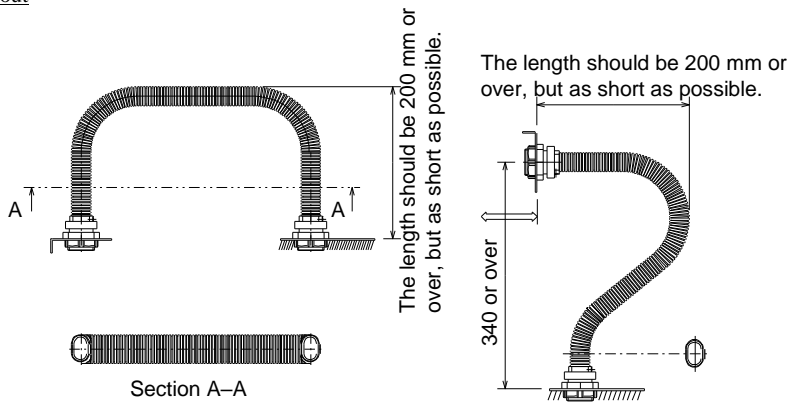

Horizontal layout

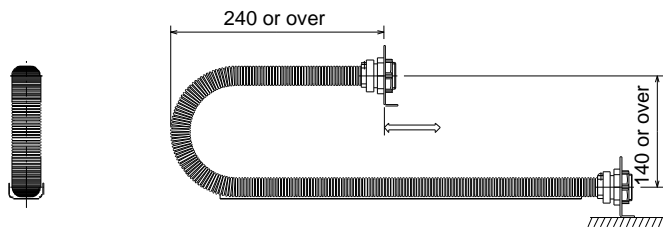

Notes

- In the “BA10-FT-M”, the controller cable does not enter. If you are using the controller cable (BE10-CC-M) through the inside of the tube, please use the “BA10-FT-L”.
- When the cross-sectional profile is round (BA10-FT-L), only the vertical layout can be used.
- If used with dimensions other than those given above, the service life of the tube will reduce drastically.
- When the axis stroke is 600 mm or over (yardstick), use of the horizontal layout or use of a flexible duct is recommended. If the vertical layout is used, the flexible tube may not function.
- DO NOT place too many cables, etc., in the tube. Otherwise, the life of the cable will reduce sharply.

- To fix both ends of the flexible tube, use fixing parts such as sheet metal prepared by the customer or it can be attached to the CN box (option).

When using the CN box, it will be a dedicated combination depending on the size of the flexible tube.

Use the combination of Flexible tube and CN box as shown in the table below.

Flexible tube		CN box that can be used in combination
M size	BA10-FT-M **	BA10-BX-B10
L size	BA10-FT-L **	BA10-BX-B20 BA10-BX-B30

The CN box is used for the purposes of relay, branch and securing when wiring and piping to the robot and hand. The CN box can be mounted on the side of the actuator (axis), motor cover end, side of the motor cover, frame other than the actuator, etc.

Example of main connection 1

[BA10-BX-B20] (Exclusively used for flexible tube L size (BA10-FT-L□□))

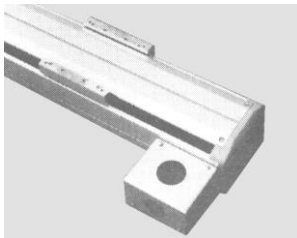

Side of axis (actuator)

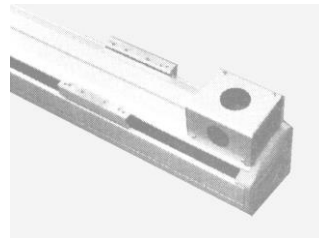

Top of actuator

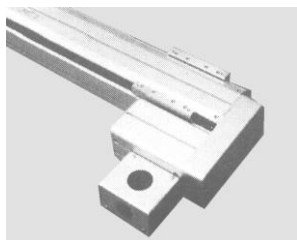

Side of motor cover

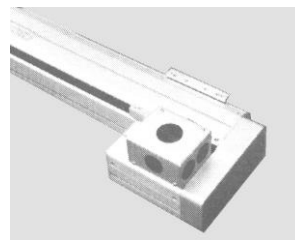

Top of motor cover

Notes

- DO NOT mount the CN box in the movable range of the slider or hand.

<Example of main connection 2>

[BA10-BX-B10] (Exclusively used for flexible tube M size (BA10-FT-M□□))

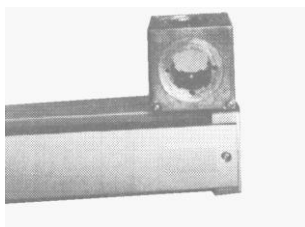

Side of axis (actuator)

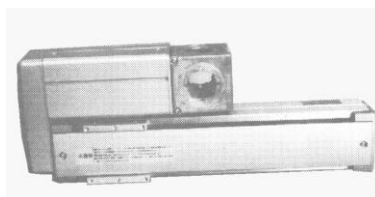

Motor cover end



Side of motor cover

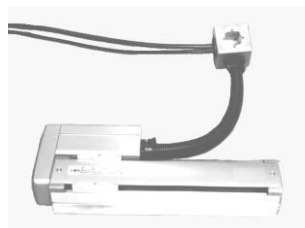

Other than actuator

Example of securing CN box 1

[BA10-BX-B20] (Exclusively used for flexible tube L size (BA10-FT-L□□))

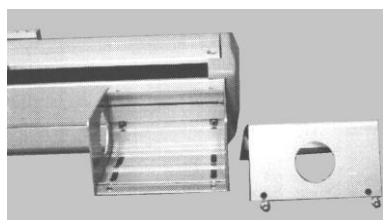
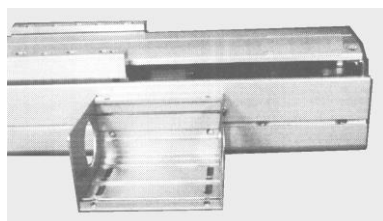
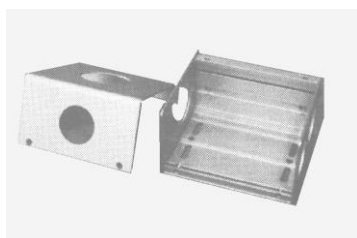

Insert the hexagon nuts into the T-slot and mount the CN box so that it will not collide with the slider.

Example of securing CN box 2 (Z-axis)

[BA10-BX-B20] (Exclusively used for flexible tube L size (BA10-FT-L□□))

Use of L-shaped metal fittings

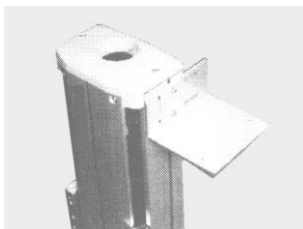

Insert the hexagon nuts into the T-slot, then secure the two (2) L-shaped metal fittings (large and small) to the side of the actuator.

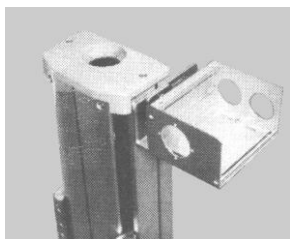

Mount the CN box on the L-shaped metal fittings so that it will not interfere with the slider.

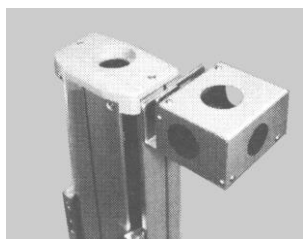

Direct mounting

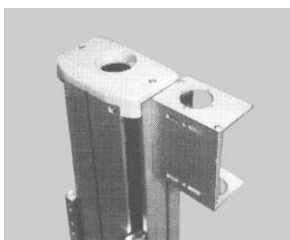

Insert the hexagon nuts into the T-slot, then secure the CN box to the side of the actuator.

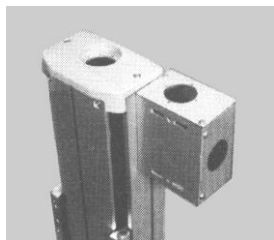

Example of securing CN box3

Use of box metal fitting

[BA10-BX-B10] (Exclusively used for flexible tube M size (BA10-FT-M□□))

Side of motor cover

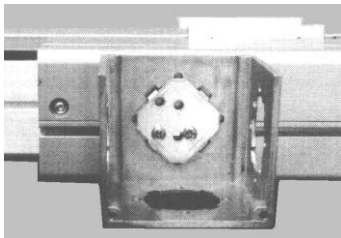
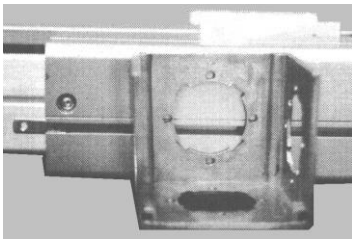
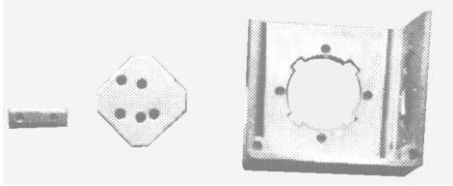

Mount the CN box so that it will not project the top of the axis (actuator) slider.

Top of motor cover

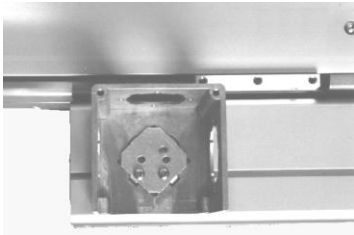
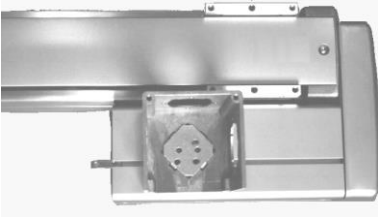
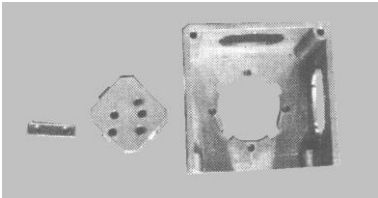

Mount the CN box so that it will not collide with the axis slider.

Side of actuator

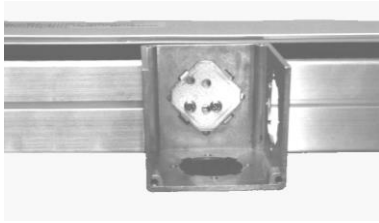

Mount the CN box so that it will not project the top of the actuator slider

Other than actuator

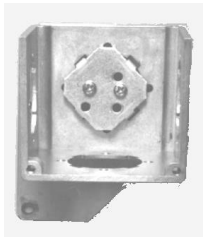

When mounting the CN box on other than the actuator, make sure that the set screws are positioned as shown below.

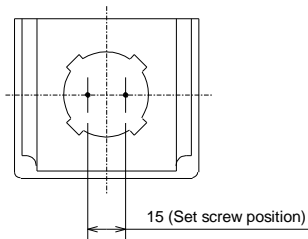

Example of flexible tube connection (BA10-FT-M**)

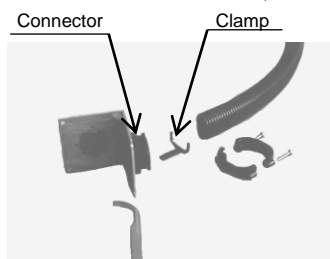

After inserting the clamp into the connector, mount the flexible tube on the connector.

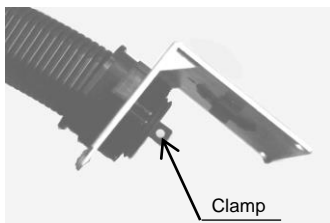

CAUTION

When using the tube, the minimum radius of curvature should be considered. For details, see the descriptions above in this paragraph.

Example of cable connection 1 (BA10-FT-L**)

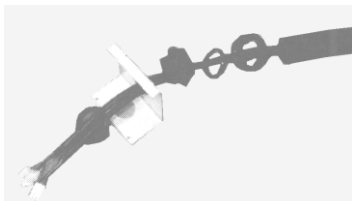

Pass all necessary parts through the cable beforehand.

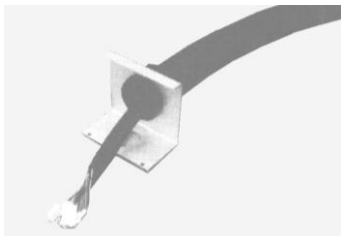

Secure the cable with the resin nut from the rear side of the CN box.

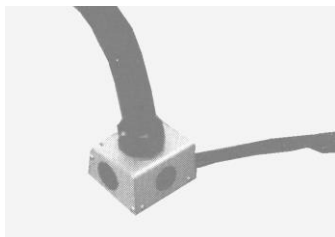
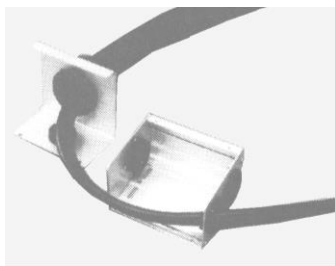

Points

- To tighten the resin nut, you can use a wrench key (option).
- Pass all necessary parts through the cable beforehand.
- DO NOT bend the flexible tube too much.

Example of cable connection 2 (BA10-FT-M**)

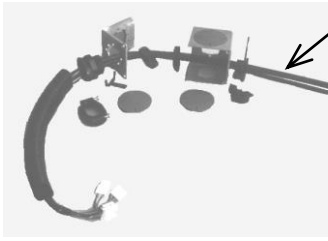

Customer wirings

CAUTION

In the “BA10-FT-M”, the controller cable does not enter.

Pass all necessary parts through the cable beforehand.

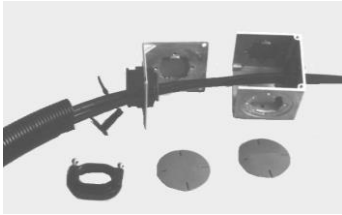

Secure the cable with a band at either the cable inlet or outlet.



Points

- To tighten the resin nut, you can use a wrench key (option).
- Pass all necessary parts through the cable beforehand.
- DO NOT bend the flexible tube too much.
- To secure the cable, use a band.

■ 3.6 Mounting, Wiring and Piping of Hand

- After installing the robot, mount the hand provided by the customer.
Make sure that the hand weight and moment load on the slider will not exceed the axis specifications.
- Use the CN box, flexible tube or flexible duct for wiring and piping to the hand.

Example of wiring and piping

Example of using sleeve cone

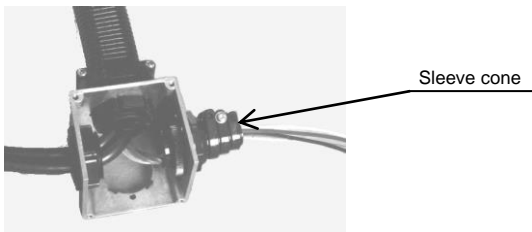

Example of using Grommet

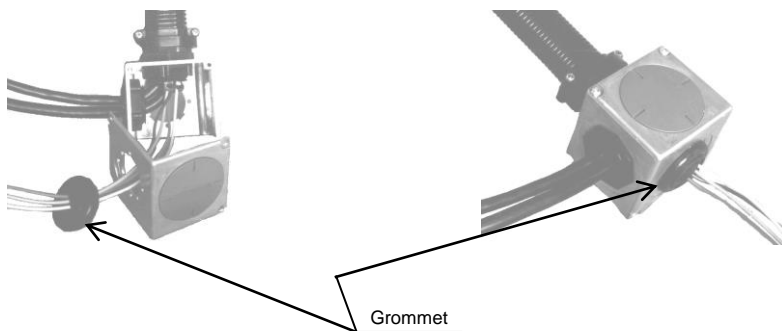

■ 3.7 Mounting Duct Tray

- The duct tray is required when the flexible duct is used on the side of the axis (actuator).
- Mount the tray so that excessive force is not exerted on the height direction and horizontal direction of the flexible duct.
- To mount the tray on the actuator, pass the hexagon nuts through the T-slot on the actuator, then secure it. See the photos below.

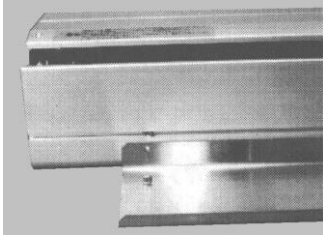
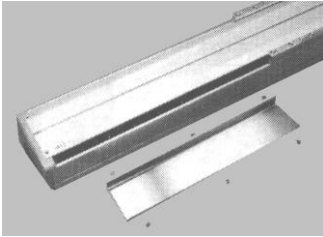

Mounting duct tray directly on the side of actuator

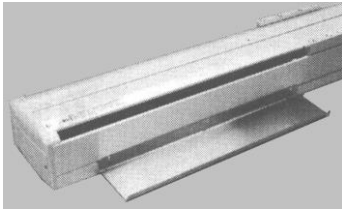

■ 3.8 Mounting Tube Tray

- The tube tray is required when the flexible tube is arranged in the horizontal condition (☐). Mount the tray so that excessive force is not exerted on the height direction and horizontal direction of the flexible tube.
- When mounting the tube tray on the axis (actuator), refer to the following photos.

Mounting tube tray on the side of actuator (using L-shaped metal fitting)

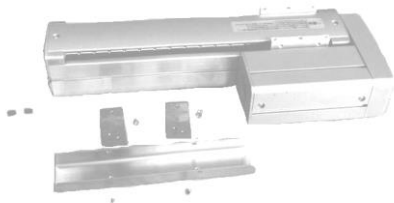

Mounting L-shaped metal fitting directly on the side of actuator



Secure the tube tray to the L-shaped metal fitting with the supplied screws.

Mounting tube tray directly on the side of actuator



Mounting tube tray directly on the side of actuator.

Mounting tube tray on the lower side of actuator

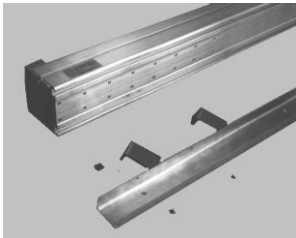

Place the included plate nut (M4) in the T groove on the bottom of the frame and fix the L-shaped metal fitting.

Mounting L-shaped metal fitting directly on the side of actuator

■ 3.9 Bolt and Nut tightening torque

For the tightening torque of bolts, etc., tighten the parts not described in the work procedure, etc. with the values in the table below.

Part name	Nominal screw size	Clamping torque (N·m)	Remarks
Hexagon socket head cap screw	M4	2.94	
	M5	5.88	
	M6	8.82	
	M8	21.6	
Pan head screw Countersunk head screw hexagon socket button head screw	M3	0.49	
	M4	1.47	
	M5	2.94	
Hexagon nut	M4	1.47	
	M5	2.94	
	M6	5.30	For T-slot mounting
	M8	12.0	For T-slot mounting
Resin nut	G1	2.94	

Chapter 4 Installing X-Y Combination Axes

■ 4.1 BE10-BE10 , BE30-BE10 (X-Y) Combination

■ 4.1.1 Example of Basic Combination

Straight axis

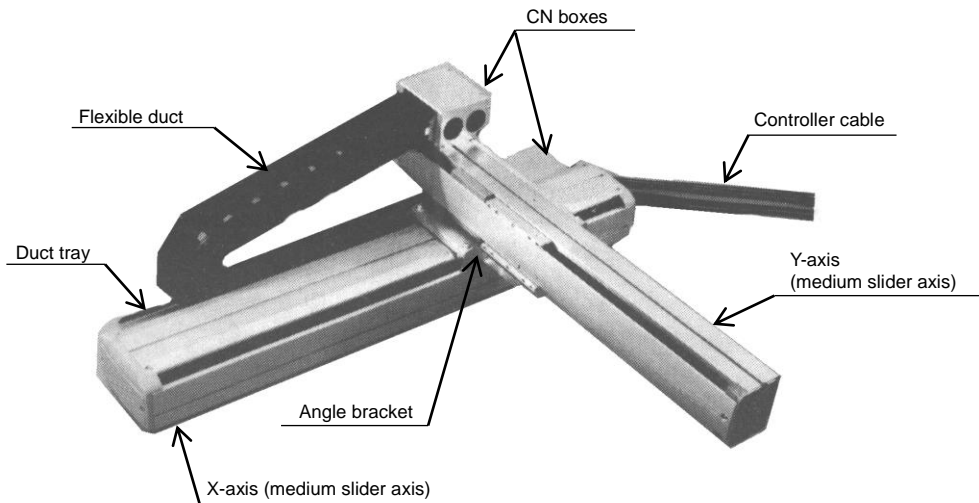

Example of laterally arranged flexible duct (between X- and Y-axes)

Points

For the precautions on flexible duct connection, see Para. 3.4.

Installation procedures (when the flexible duct is used)

- (1) Install the 1st axis (actuator).
- (2) Mount the angle bracket.
- (3) Mount the 2nd axis (actuator).
- (4) Mount the CN box.
- (5) Prepare the flexible duct of an appropriate length. Pass the required parts through the cables, then pass the cables through the duct.
- (6) Secure the cables in turn, starting from the Y-axis (2nd axis) motor side.
- (7) Secure the cables with band.
- (8) Mount the CN box cover.

Points

For details, see Section 3.

(1), (2)

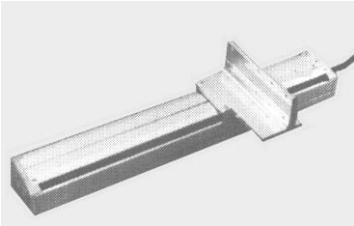

(3)

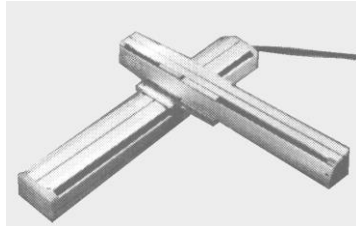

(4)

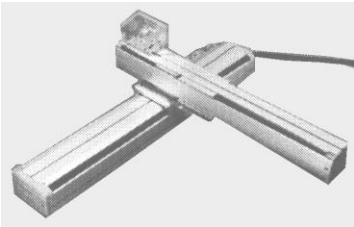

(5)-1

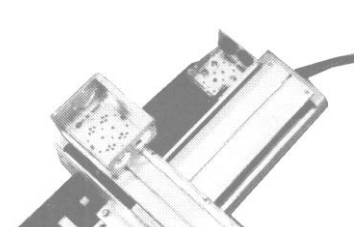

(5)-2

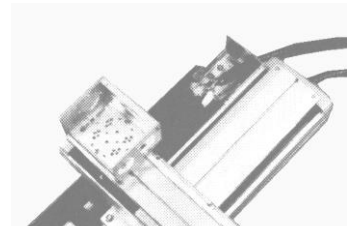

(5)-3

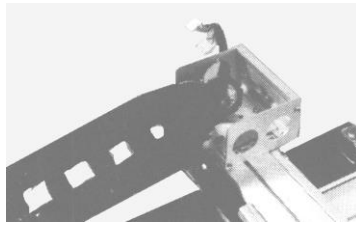

(6)

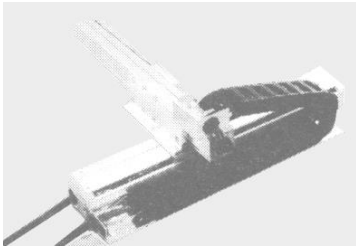

(7)-1

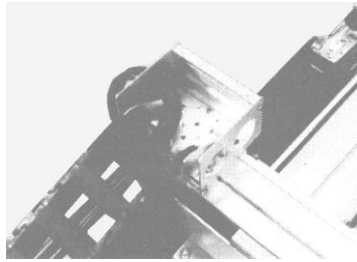

(7)-2

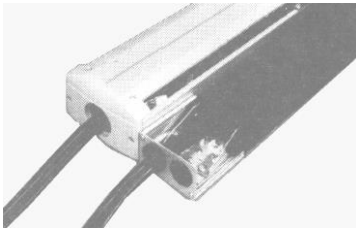

(8)

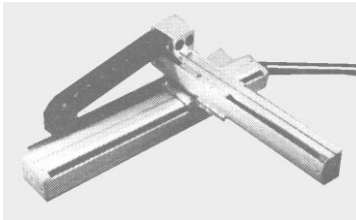
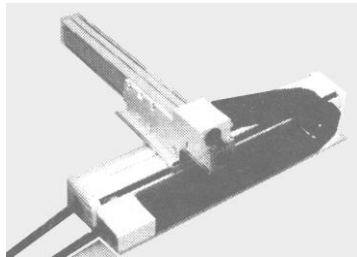

Completion form of combination

■ 4.2 BE50-BE30 (X-Y) Combination

■ 4.2.1 Example of Basic Combination

Straight axis

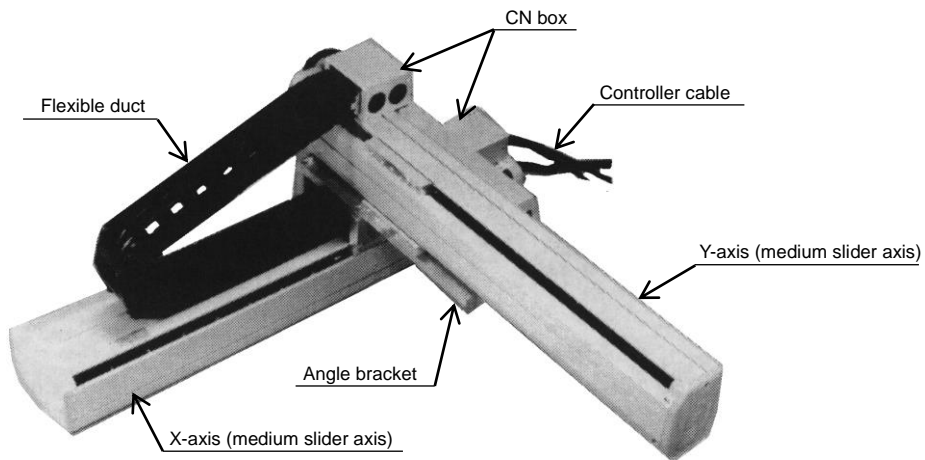

Example of laterally arranged flexible duct (between X- and Y-axes)

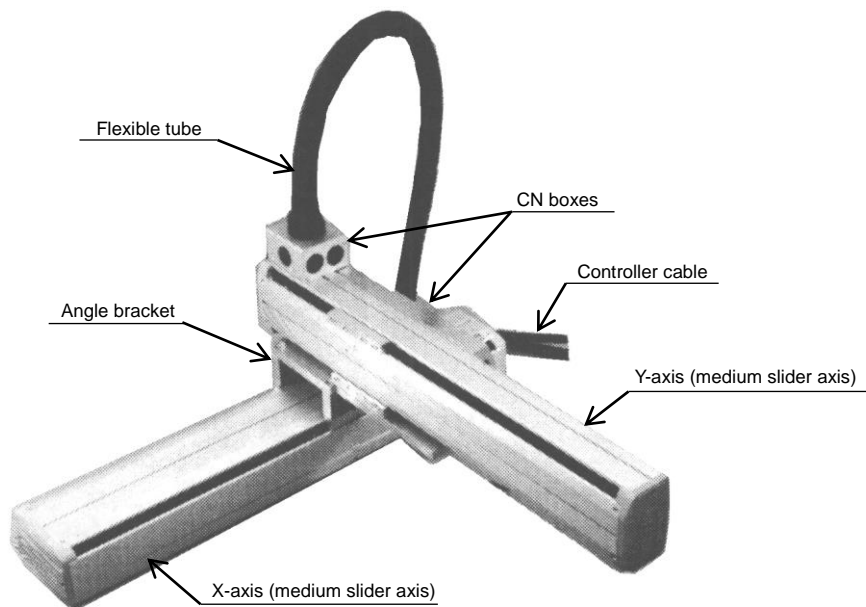

Example of horizontally arranged flexible tube

Points

- For the precautions on flexible duct connection, see Para. 3.4.
- For the precautions on flexible tube connection, see Para. 3.5.

Installation procedures (when the flexible duct is used)

- (1) Install the 1st axis (actuator).
- (2) Mount the angle bracket.
- (3) Mount the 2nd axis (actuator).
- (4) Mount the CN box.
- (5) Prepare the flexible duct of an appropriate length. Pass the required parts through the cables, then pass the cables through the duct.
- (6) Secure the cables in turn, starting from the Y-axis (2nd axis) motor side.
- (7) Secure the cables with band.
- (8) Mount the CN box cover.

Points

For details, see Section 3.

(1), (2)

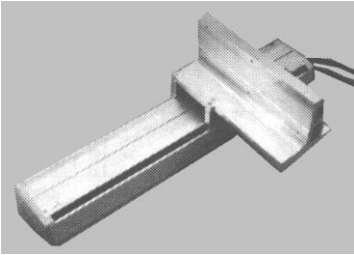

(3)

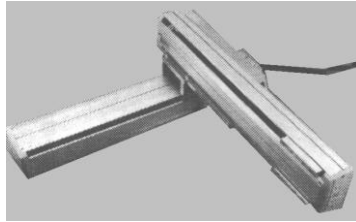

(4)

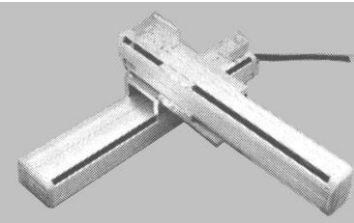

(5)-1

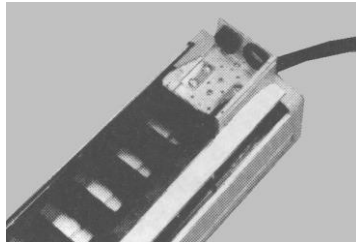

(5)-2

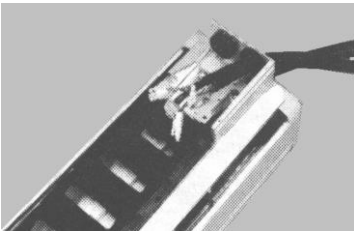

(5)-3

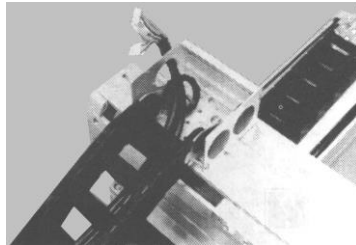

(6)

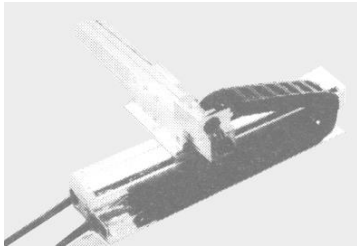

(7)-1

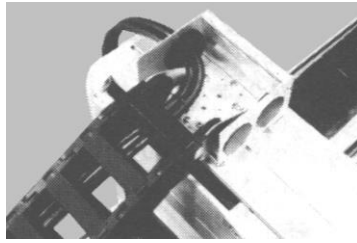

(7)-2

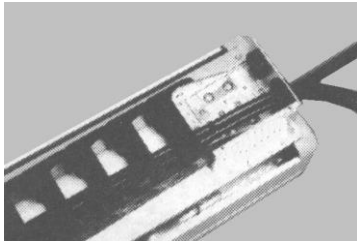

(8)

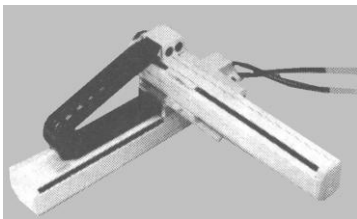
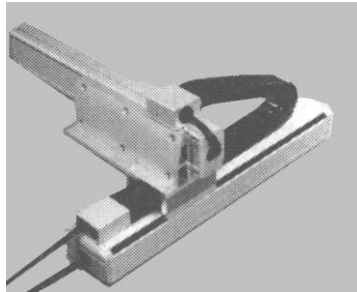

Completion form of combination

Installation procedures (when the flexible tube is used)

- (1) Install the 1st axis (actuator).
- (2) Mount the angle bracket.
- (3) Mount the 2nd axis (actuator).
- (4) Mount the CN box.
- (5) Cut the flexible tube to an appropriate length. Pass the required parts through the cables, then pass the cables through the tube.
- (6) Secure the cables in turn, starting from the Y-axis (2nd axis) motor side.
- (7) Secure the cables with band.
- (8) Mount the CN box cover.

Points

For details, see Section 3.

(1), (2)

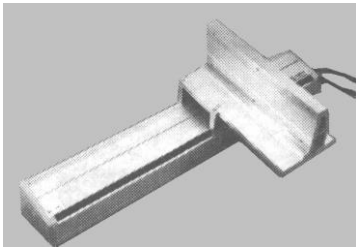

(3)

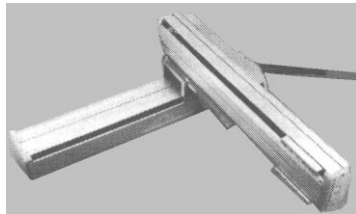

(4)

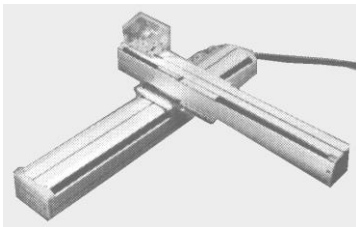

(5)-1

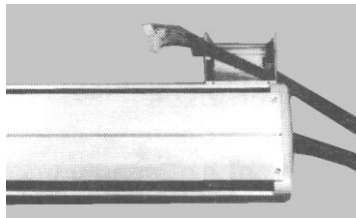

(5)-2

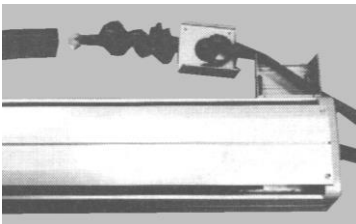

(5)-3

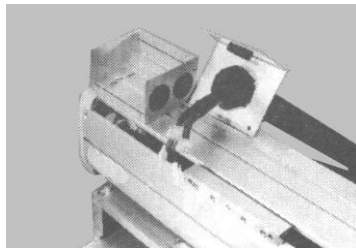

(6)

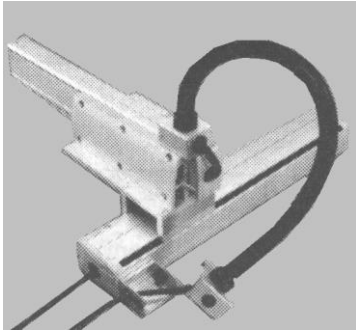

(7)

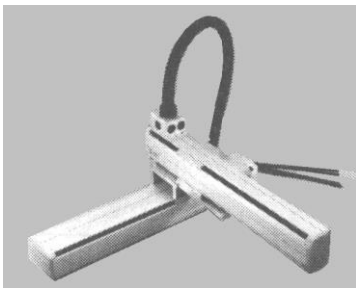
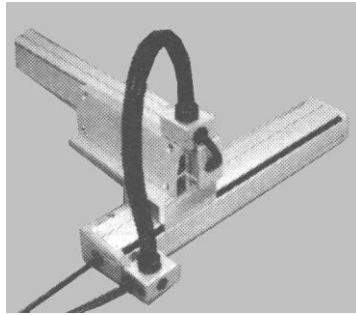

Completion form of combination

Chapter 5 Installing X-Y-Z Combination Axes

■ 5.1 BE50-BE30-BE10 (X-Y-Z) Combination

■ 5.1.1 Example of Basic Combination

Straight axis

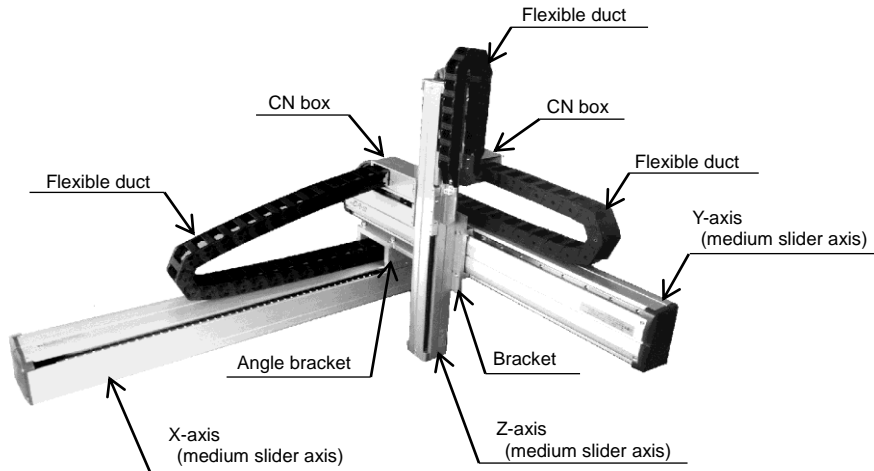

Example of laterally arranged flexible duct

Points

For the precautions on flexible duct connection, see Para. 3.4.

Installation procedures (when the flexible duct is used)

- (1) Install the 1st axis (actuator).
- (2) Mount the angle bracket to the 1st axis slider.
- (3) Mount the 2nd axis (actuator).
- (4) Mount the angle bracket to the 2nd axis slider.
- (5) Mount the 3rd axis (actuator).
- (6) Mount the CN box bracket to the 3rd axis.
- (7) Mount the flexible duct bracket (moving side) to the 3rd axis slider.
- (8) Mount the flexible duct bracket (Fixed side) to the 3rd axis frame.
- (9) Mount the CN box to the 1st axis frame cover.
- (10) Mount the CN box to the 2nd axis frame.
- (11) Mount the CN box to the CN box bracket on the 3rd axis.
- (12) Prepare the flexible duct for XY to an appropriate length.
Mount the flexible duct(Fixed side) to the 1st axis CN box.
- (13) Mount the flexible duct (moving side) to the 2nd axis CN box.
- (14) Prepare the flexible duct for YZ to an appropriate length.
Mount the flexible duct(Fixed side) to the 2nd axis CN box.
- (15) Mount the flexible duct (moving side) to the 3rd axis CN box.
- (16) Mount the flexible duct to the 3rd axis flexible duct bracket.
- (17) Pass the required parts through the cables, then pass the cables through the duct.
- (18) Pass the cable through the hole in the 2nd axis CN box.
- (19) Wire to the motor of the 2nd axis.
- (20) Pass the cable through the hole in the 3rd axis CN box. Wire to the motor of the 3rd axis.
- (21) Secure the cable with the band and mount the CN box cover.

Points

For details, see Section 3.

(1)

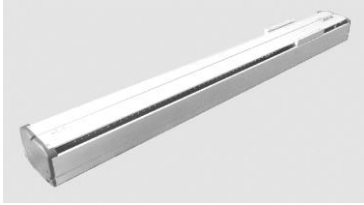

(2)

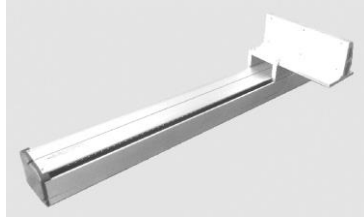

(3)

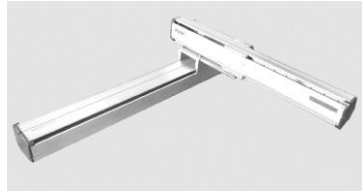

(4)

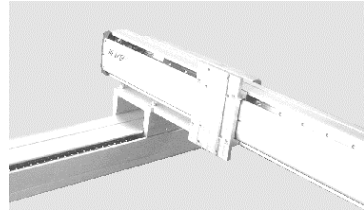

(5)

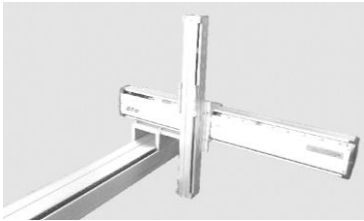

(6)



(7)

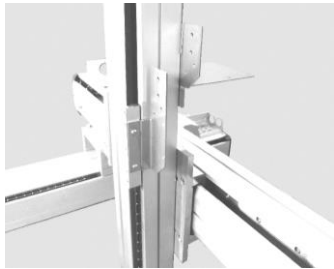

(8)

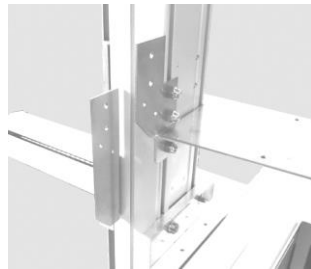

(9)

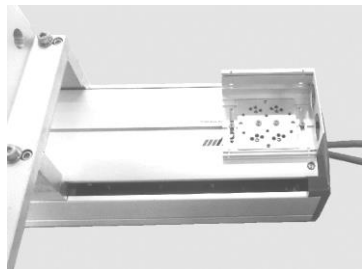

(10)

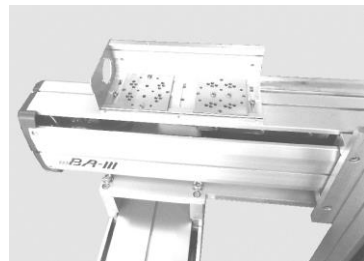

(11)

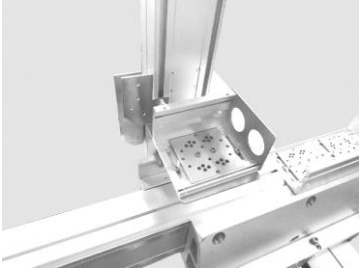

(12)

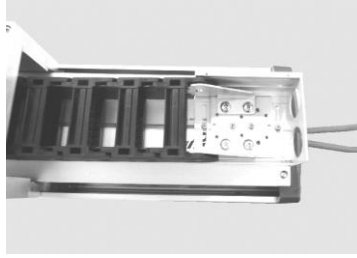

(13)

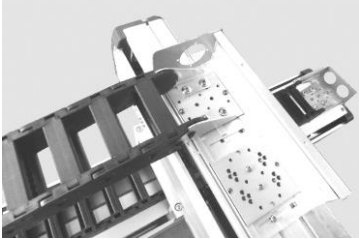

(14)

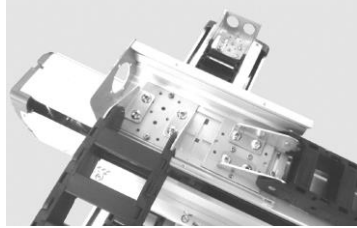

(15)

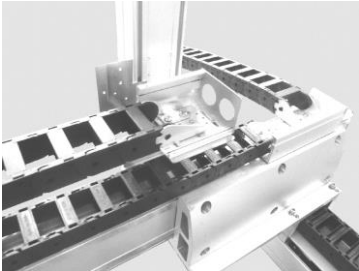

(16)

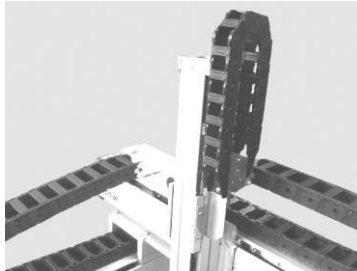

(17)

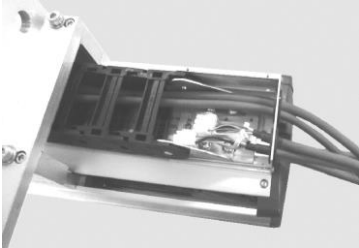

(18)

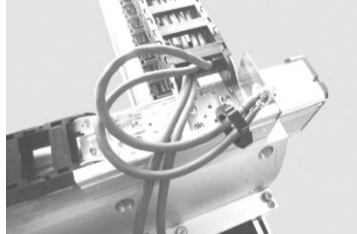

(19)

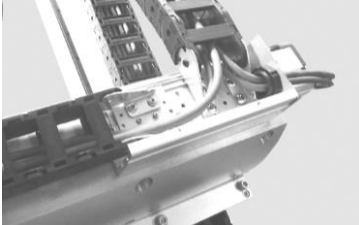

(20)

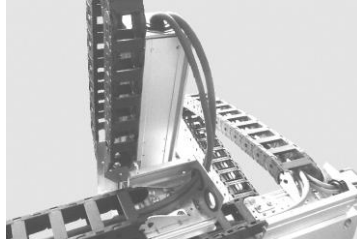

(21)

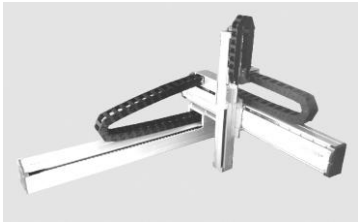
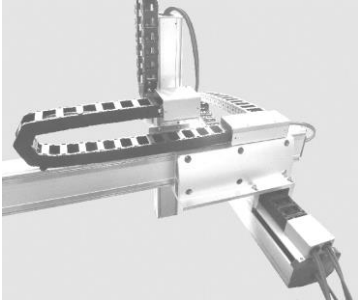

Completion form of combination

Chapter 6 Maintenance and Inspection

■ 6.1 Cautions on Maintenance and Inspection

(1) Cautions on maintenance and inspection

When performing inspection and maintenance, observe the following matters.

1. Maintenance and inspection of the robot should be performed only by a qualified person well versed in the knowledge and having experiences. Unless such a person is present, consult with the manufacturer to take necessary measures such as having the relevant work done by the manufacturer or having the customer's responsible persons trained for the work by the manufacturer.
2. Use an appropriate illumination.
3. Put a tag showing "Under inspection (or maintenance)" on the start switch, etc., equipped on the stationary operation panel.
When entering the fence or premises, lock the power switch which is turned off to completely cut off the power. If the safety plug is attached to the entry of the fence or premises, carry it with you.
4. When you have to enter the fence or premises for inspection or maintenance of the control circuit, be sure to shut off the drive power source beforehand.
5. When you have to operate the industrial robot for inspection or maintenance inside the fence or premises, it is recommended to take the measures prescribed below.
 - The work should be performed by two (2) persons. That is, when one person executes the work, the other person keeps a watch.
 - The robot speed is desirably such that can avoid contact with the worker should the robot move unexpectedly. Determine the appropriate speed according to the work to be done.
 - During the work, take careful precautions on the robot motions. If the robot has not moved just as you intended, immediately press the EMERGENCY STOP pushbutton switch.
6. Before disassembling the air pressure gage, etc., or replacing the part, release the residual pressure from the cylinder.
7. When disassembling the hydraulic or pneumatic circuit or replacing the part, take utmost care not to allow adhesion or entry of contaminant.
8. Before turning on the power, make sure that the ground wire is connected.
If you touch the robot, you will get an electric shock due to the leakage current.
9. Don't place equipment that generates excessive noise near the robot.
Collision could be happen with the robot that has malfunctioned due to noise.
10. Before servo-on the robot, make sure that no one is within the robot's range of motion.
The person inside is struck by the robot that has moved.
11. Do not modify anything other than the permitted parts.
A broken robot causes an unexpected disaster.
12. The equipment **MUST NOT** be repaired or modified without prior written permission from the manufacturer.
Otherwise, an accident or damage will be caused.
13. Be sure to perform regular maintenance and inspection.
If maintenance and inspection are neglected, a broken robot could cause an unexpected disaster.
14. Before touching the robot, make sure that the surface temperature is below 50°C.
If you touch the hot motor or the area around the motor, you will get burned.
 - If necessary, wear protective gloves.
15. Use a hand with a structure and wiring that does not release the work even if the power supply of the robot or the drive source of the hand is cut off.
 - Perform daily inspections of the air tube connected to the hand, and replace it if it is damaged.
 - Install a fence to prevent falling and flying objects.

16. Be sure to replace with the maintenance replacement parts specified by our company.
Using unspecified parts will cause an unexpected disaster.
 - When ordering maintenance replacement parts, be sure to contact us.
 - Be sure to contact our service company for replacement work other than the encoder battery. We support for a fee.
 - We will not compensate for accidents or damages caused by the replacement work performed by the customer and the result.
17. When it gets on the skin or in the eyes, it causes inflammation.
 - When applying, please wear protective gloves.
 - Should this get on your skin, rinse with plenty of water and soap.
 - Should this get in your eyes, rinse with plenty of running water and then consult a doctor.

(2) Measures to be taken at the end of inspection and maintenance

1. Persons in charge of inspection and maintenance should return all tools to the predetermined place after the work has finished.
2. After the maintenance, be sure to test-run the equipment for confirmation. In principle, the test-run for confirmation should be performed from outside the fence or premises.
3. After the work in Item 2 above has been performed, persons responsible for inspection and maintenance should report their manager that the inspection or maintenance has completed.

■ 6.2 Inspection before Starting Operation

- (1) Before starting the robot operation, perform check on the following matters.
 1. Function of control unit.
 2. Function of emergency stop switch.
 3. Function of robot interlock with equipment for preventing contact.
 4. Function of robot interlock with related equipment.
 5. Damage of external power supply, piping, etc.
 6. Abnormality of supply voltage, supply hydraulic pressure and supply pressure.
 7. Nonconformity of operation.
 8. Abnormal noise and abnormal vibration.
 9. Condition of equipment for preventing contact.
- (2) Execute the inspection outside the working envelope, where possible.

■ 6.3 Regular Inspection

Determine the inspection standard including the check items, method, criteria for evaluation and time of execution for the following items, considering the robot installation place, frequency of use and durability of parts, then execute the inspection according to the same standard.

1. Looseness of main parts.
2. Lubrication state of movable parts and other abnormality of movable parts.
3. Abnormality of power transmission parts.
4. Abnormality of hydraulic and pneumatic circuits.
5. Abnormality of electric circuit.
6. Abnormality of function detecting a motion error.
7. Abnormality of encoder.
8. Abnormality of servo system.

[Check points of controller]

9. Make sure that the supply voltage to the controller falls under the predetermined range (i.e., rated voltage $\pm 10\%$).
10. Check for the air vent holes on the controller, and remove contaminant if any left on them.
11. Check for the controller cable (running from the controller to the actuator) and make sure that all screws, etc., are tightened completely.
12. Make sure that the controller set screws, etc., are tightened completely.
13. Check for each connector (motor output connector, encoder input connector, teach pendant connector) and make sure that they are tightened completely, not causing gap.

■ 6.4 Maintenance and inspection work

For maintenance and inspection items, refer to the actuator instruction manual.

■6.5 Lubricating Each Part

For lubrication method, please refer to each actuator instruction manual.

■6.6 Cleaning

For cleaning of each part, please refer to each actuator instruction manual.

■6.7 Spare Parts

■6.7.1 Spare parts of actuator

For spare parts of the actuator, please refer to each actuator instruction manual.

Chapter 7 Product disposal

■ 7.1 Product disposal

When disposing of this product, treat it as industrial waste.

When disposing, please separate them as much as possible.

Regarding the classification of waste, please handle it according to your company's regulations and the rules of each local government and industrial waste disposal company.

CAUTION

- (1) Dispose or recycle encoder batteries according to your company's and local rules.
Inflammation is caused when the liquid leaked by incineration, decomposition, recharging, or heating gets on the skin or in the eyes.
 - When the leaked liquid should get on your skin, rinse immediately with running water.
 - When the leaked liquid should get in your eyes, rinse immediately with running water and get a medical examination by a doctor.
 - Insulate the terminals of the used battery with tape or the like.
- (2) Regarding repackaging and transportation at the time of disposal, please check and comply with the precautions listed in “■ 1.2.2 Precautions during transportation” and “■ 1.2.3 Notes on unpacking and repacking” please do the work.
- (3) Place the robot in a stable position at the disposal site.
Otherwise, the robot will fall down.
If possible, ensure safety and then lay it on its side.
- (4) Be sure to store the cables that crawl on the floor in a duct or the like.
Stumbling and falling could occur.
Wear a helmet to protect your head.

SHIBAURA MACHINE CO., LTD.

TOKYO HEADQUARTERS

Electronic Equipment Sales Group, Control Systems Division
2-2, Uchisaiwaicho 2-Chome, Chiyoda-ku, Tokyo 100-8503, Japan
TEL: [81]-(0)3-0270 FAX: [81]-(0)3-3509-0335