

Move envelope

Scale 1:6

Battery case

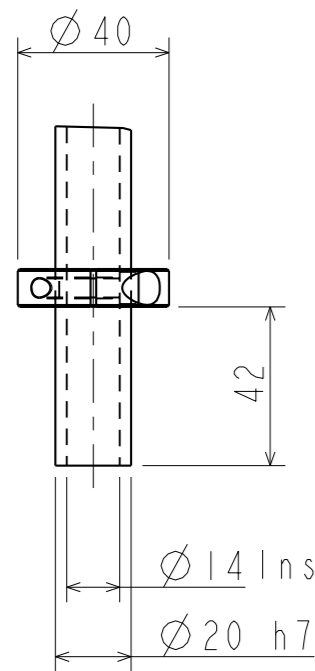

Ø14 Inside diameter of ball screw

Ø20 h7

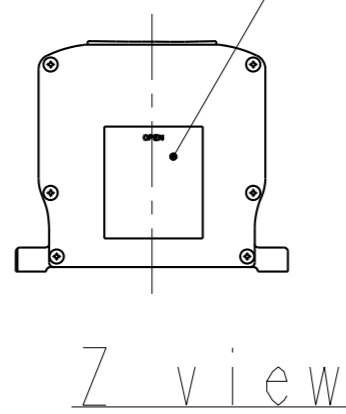

Z view

Detail installation view of hand

Scale 1:2

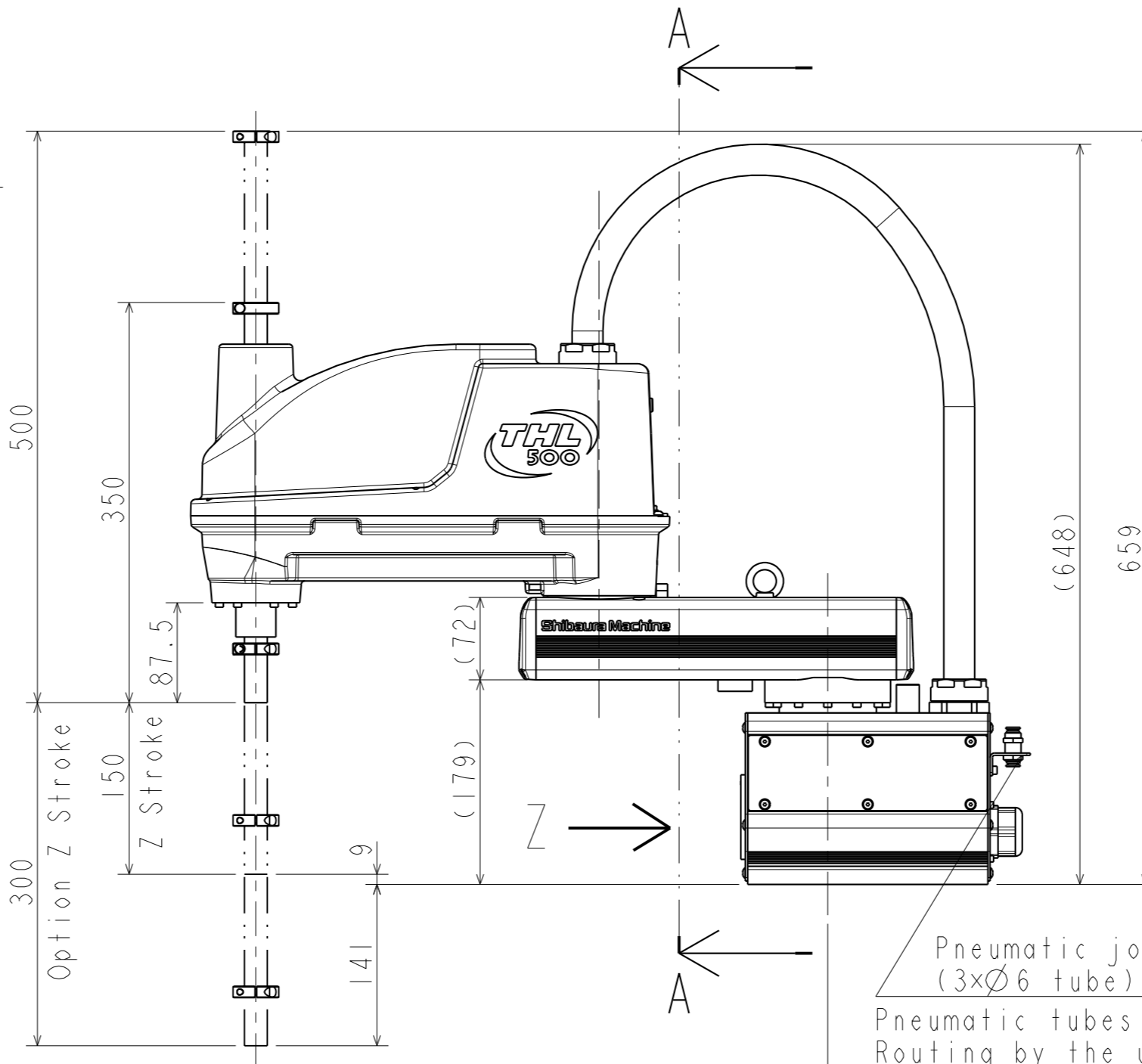
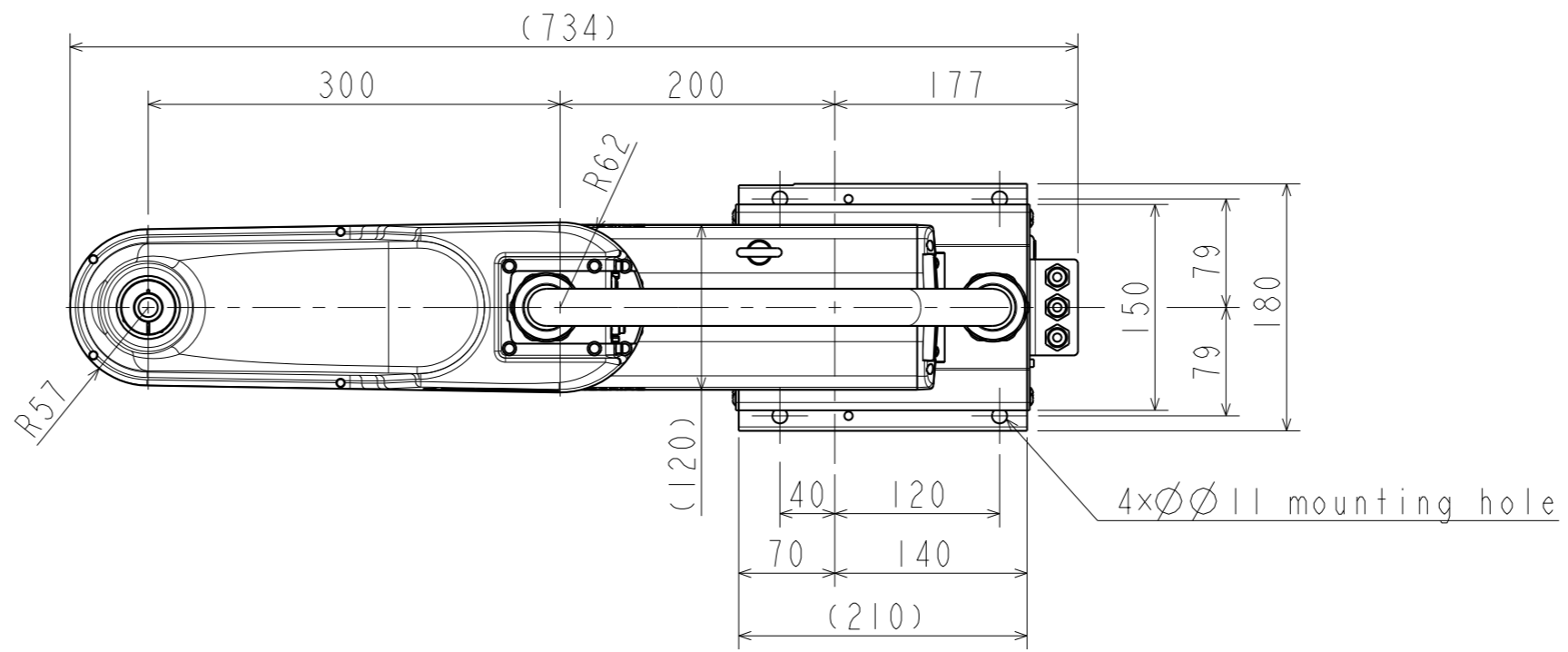

Option Z Stroke

Z Stroke

Z

Pneumatic joint for users (3xØ6 tube)  
Pneumatic tubes are included.  
Routing by the user.

(295)  
Space for cable approx

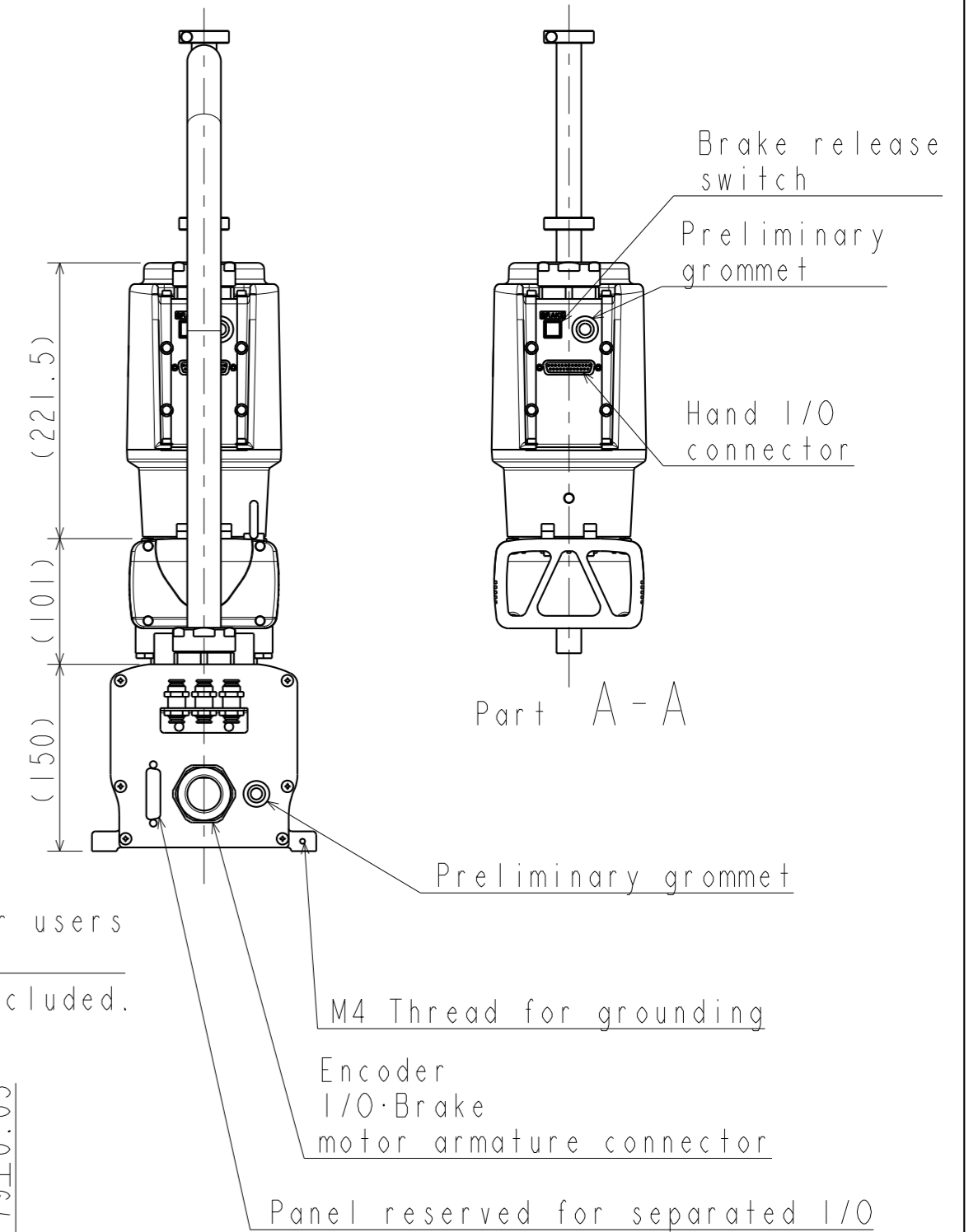
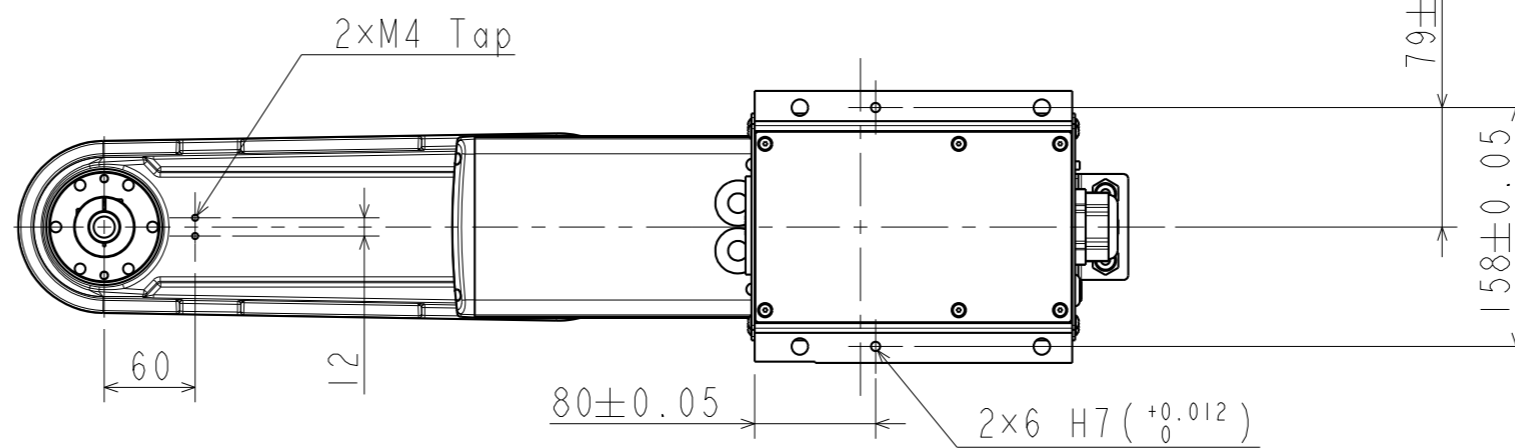

Part A-A

M4 Thread for grounding

Encoder I/O-Brake motor armature connector

Panel reserved for separated I/O

System Robot Outline  
Scale 1:5

THL500

SHIBAURA MACHINE CO., LTD. S-26V83-3