

Working Envelope
Scale 1:3

2xM4 Thread
for peripheral
device fixture
both side

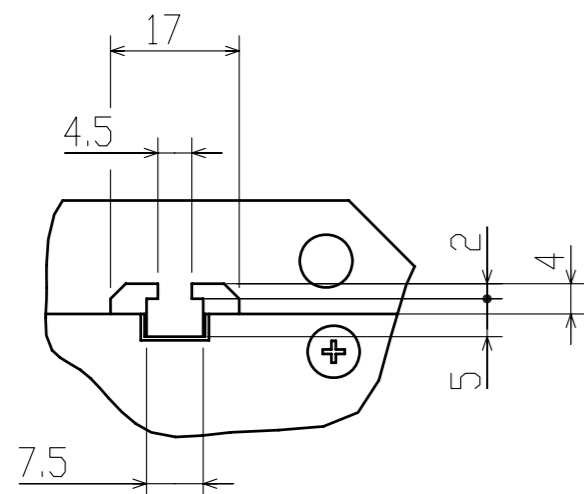

T-shaped thread
for peripheral
device fixture

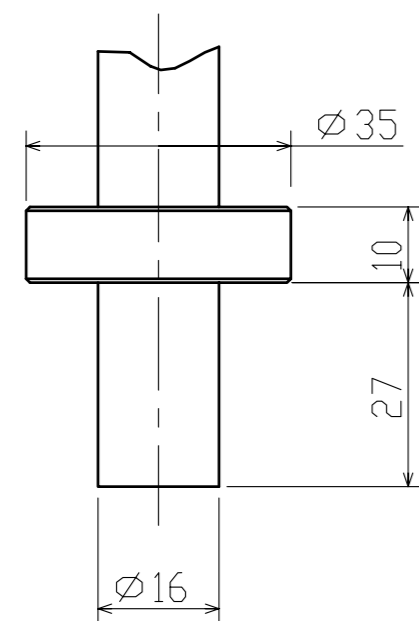

Detail of tool shaft

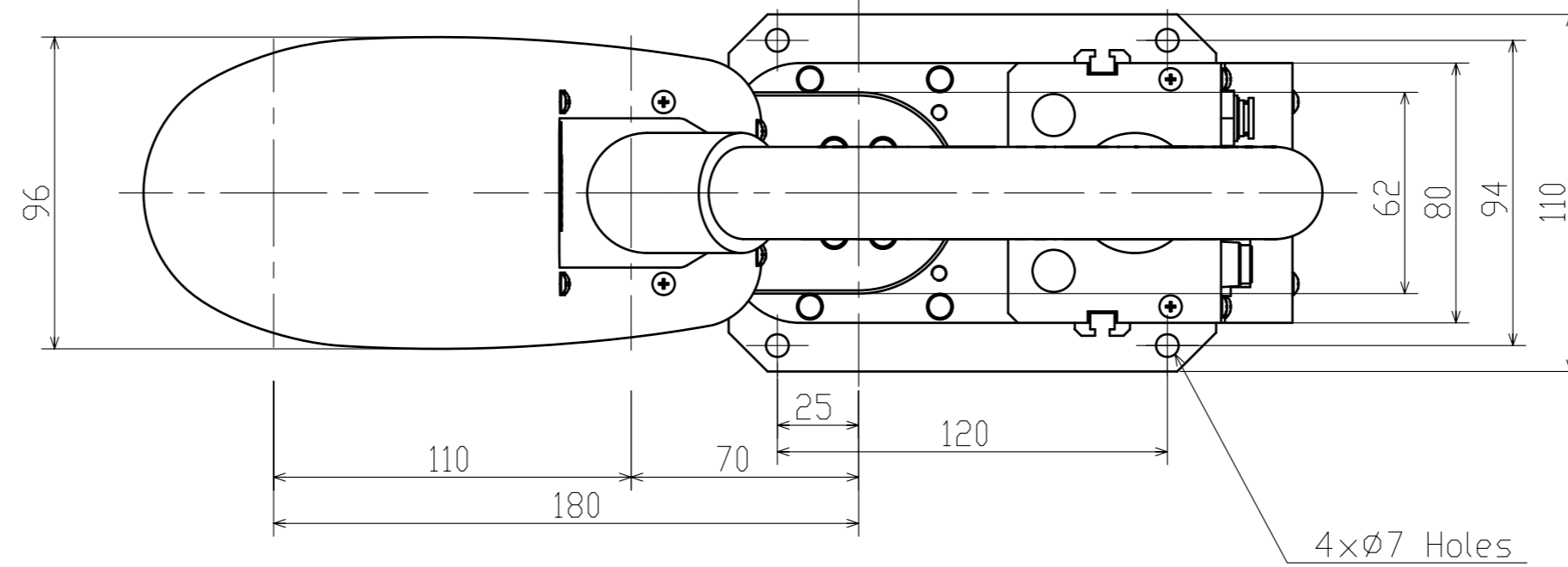

4xφ7 Holes

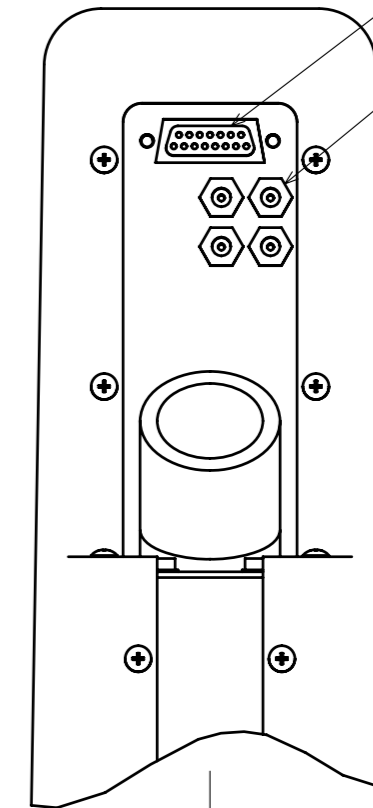

Hand I/O connector
4xM5 Thread for
pneumatic joint

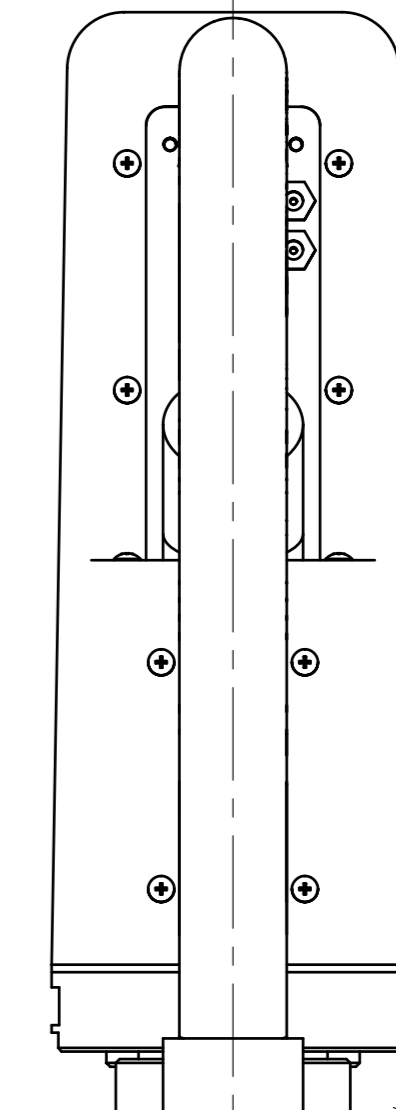

Pneumatic joint
for vacuum
(φ6 tube)

Pneumatic joint
for users
(4xφ4 tube)

Hand I/O connector

Encoder connector

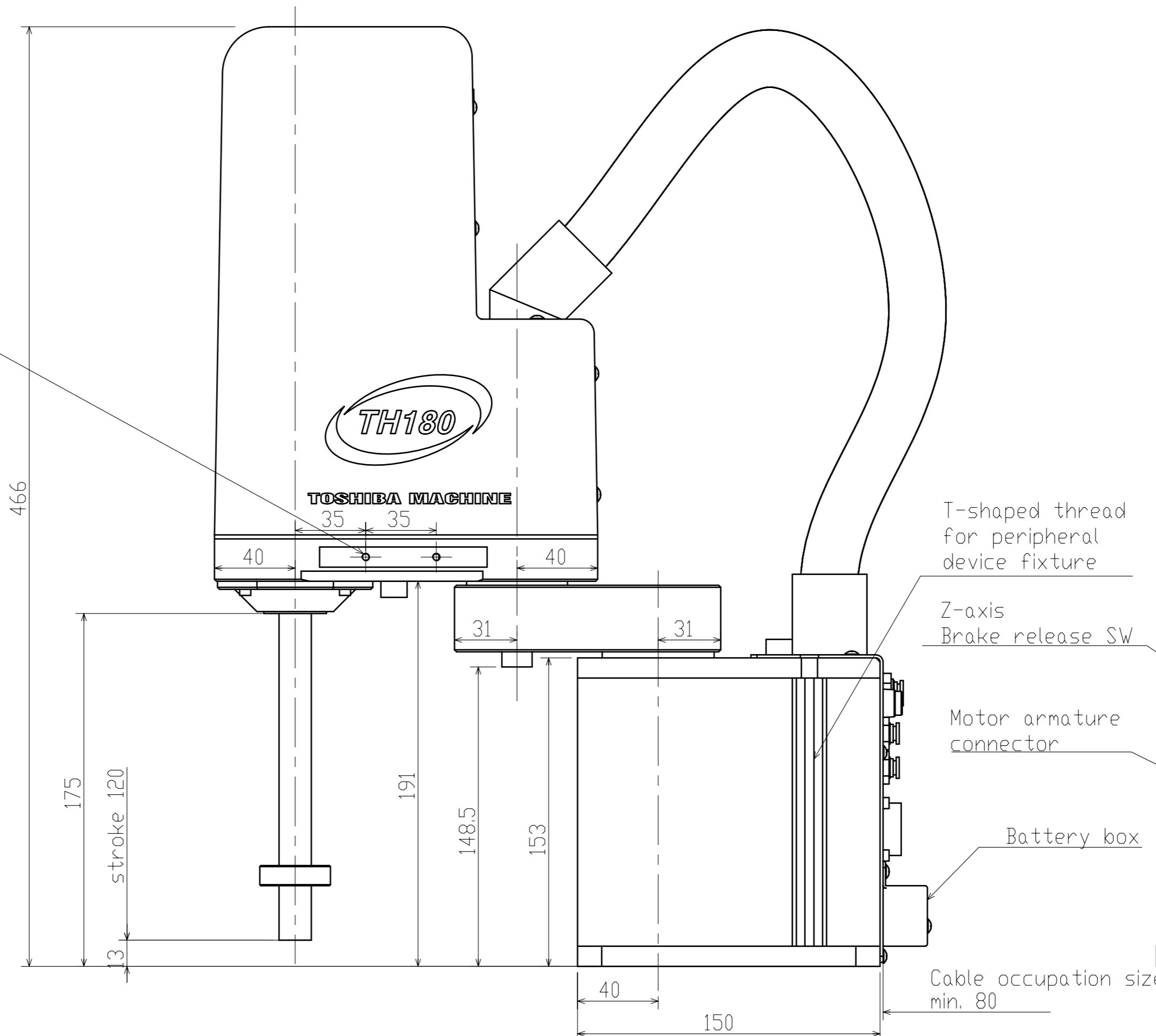

T-shaped thread
for peripheral
device fixture

Z-axis
Brake release SW

Motor armature
connector

Battery box

Cable occupation size
min. 80

System robot
Outline

TH180

TOSHIBA MACHINE Co.,Ltd. S-23L36